



# DOCUMENTATION ISG-kernel

## Functional description Improved position control

Short Description:  
FCT-A12

© Copyright  
ISG Industrielle Steuerungstechnik GmbH  
STEP, Gropiusplatz 10  
D-70563 Stuttgart  
All rights reserved  
[www.isg-stuttgart.de](http://www.isg-stuttgart.de)  
[support@isg-stuttgart.de](mailto:support@isg-stuttgart.de)

Documentation version: 1.03  
08/07/2024

# Preface

## Legal information

---

This documentation was produced with utmost care. The products and scope of functions described are under continuous development. We reserve the right to revise and amend the documentation at any time and without prior notice.

No claims may be made for products which have already been delivered if such claims are based on the specifications, figures and descriptions contained in this documentation.

## Personnel qualifications

---

This description is solely intended for skilled technicians who were trained in control, automation and drive systems and who are familiar with the applicable standards, the relevant documentation and the machining application.

It is absolutely vital to refer to this documentation, the instructions below and the explanations to carry out installation and commissioning work. Skilled technicians are under the obligation to use the documentation duly published for every installation and commissioning operation.

Skilled technicians must ensure that the application or use of the products described fulfil all safety requirements including all applicable laws, regulations, provisions and standards.

## Further information

---

Links below (DE)

<https://www.isg-stuttgart.de/produkte/softwareprodukte/isg-kernel/dokumente-und-downloads>

or (EN)

<https://www.isg-stuttgart.de/en/products/softwareproducts/isg-kernel/documents-and-downloads>

contains further information on messages generated in the NC kernel, online help, PLC libraries, tools, etc. in addition to the current documentation.

## Disclaimer

---

It is forbidden to make any changes to the software configuration which are not contained in the options described in this documentation.

## Trade marks and patents

---

The name ISG®, ISG kernel®, ISG virtuos®, ISG dirigent® and the associated logos are registered and licensed trade marks of ISG Industrielle Steuerungstechnik GmbH.

The use of other trade marks or logos contained in this documentation by third parties may result in a violation of the rights of the respective trade mark owners.

## Copyright

---

© ISG Industrielle Steuerungstechnik GmbH, Stuttgart, Germany.

No parts of this document may be reproduced, transmitted or exploited in any form without prior consent. Non-compliance may result in liability for damages. All rights reserved with regard to the registration of patents, utility models or industrial designs.

# General and safety instructions

## Icons used and their meanings

This documentation uses the following icons next to the safety instruction and the associated text. Please read the (safety) instructions carefully and comply with them at all times.

## Icons in explanatory text

➤ Indicates an action.

⇒ Indicates an action statement.



### **DANGER**

#### **Acute danger to life!**

If you fail to comply with the safety instruction next to this icon, there is immediate danger to human life and health.



### **CAUTION**

#### **Personal injury and damage to machines!**

If you fail to comply with the safety instruction next to this icon, it may result in personal injury or damage to machines.



### **Attention**

#### **Restriction or error**

This icon describes restrictions or warns of errors.



### **Notice**

#### **Tips and other notes**

This icon indicates information to assist in general understanding or to provide additional information.



### **Example**

#### **General example**

Example that clarifies the text.



### **Programming Example**

#### **NC programming example**

Programming example (complete NC program or program sequence) of the described function or NC command.



### **Release Note**

#### **Specific version information**

Optional or restricted function. The availability of this function depends on the configuration and the scope of the version.

# Table of contents

<b>Preface</b> .....	<b>2</b>
<b>General and safety instructions</b> .....	<b>3</b>
<b>1 Overview</b> .....	<b>5</b>
<b>2 Description</b> .....	<b>6</b>
2.1 "DIRECT" mode .....	7
2.2 "INDIRECT" mode.....	8
2.3 "SET_POINT" mode.....	9
<b>3 Enabling</b> .....	<b>10</b>
3.1 Prerequisites .....	10
3.2 Gantry axes.....	11
3.3 Application example .....	11
<b>4 Parameter</b> .....	<b>15</b>
4.1 Overview .....	15
4.2 Description .....	16
<b>5 Appendix</b> .....	<b>23</b>
5.1 Suggestions, corrections and the latest documentation.....	23
<b>Keyword index</b> .....	<b>24</b>

# 1 Overview

## Task

Mechanical vibrations have a direct impact on the dynamics and machining results of machine tools. The following factors cause excitation in the machine in particular:

- the natural frequencies of the machine and
- frequencies impacting the machine from external influences.

The "Improved Position Control" function provides active damping of these mechanical vibrations by control mechanisms.



### Release Note

**This function is available as of CNC Build V3.1.3077.08.**

## Effectiveness

The active damping of vibrations allows the setting of a higher proportional gain factor ( $K_v$ ) in the position control loop. This results in

- better dynamics,
- shorter machining times and
- better workpiece quality.

The possible applications include axes where individual frequencies affect the quality of machining.

## Parameterisation

The "Improved Position Control" function is parameterised [▶ 15] for each single axis in the axis parameters.

An exception to this are gantry slave axes. In this case, the parameters are adopted internally directly from the master axis.

## Mandatory note on references to other documents

For the sake of clarity, links to other documents and parameters are abbreviated, e.g. [PROG] for the Programming Manual or P-AXIS-00001 for an axis parameter.

For technical reasons, these links only function in the Online Help (HTML5, CHM) but not in pdf files since pdfs do not support cross-linking.

## 2 Description

Machine vibrations can often not be prevented during machining. The "Improved Position Control" function provides a flexible solution to counteract the problem of natural vibrations by adapting various parameters.

Vibrations are actively damped by extending the classic PPI cascade control to allow an additional feedback of filtered speed values. Up to 3 frequencies can be damped simultaneously.

Parameterisation is carried out using P-AXIS-00753 [▶ 17] and 3 modes are available for each frequency:

- (NOT\_ACTIVE = 0)
- DIRECT = 1
- INDIRECT = 2
- SET\_POINT = 3

The operating principle of modes 1 - 3 is described in the sections below.



### Attention

**The "Improved Position Control" function is an intervention in the control loop and is therefore critical for system stability.**

## 2.1 "DIRECT" mode

"DIRECT" mode (P-AXIS-00753 [▶ 17]) only uses direct measured values to dampen vibrations; the vibrations to be damped (P-AXIS-00751 [▶ 16]) must therefore be contained in the actual values.

The figure below shows the extension of the PPI cascade rule for "DIRECT" mode:

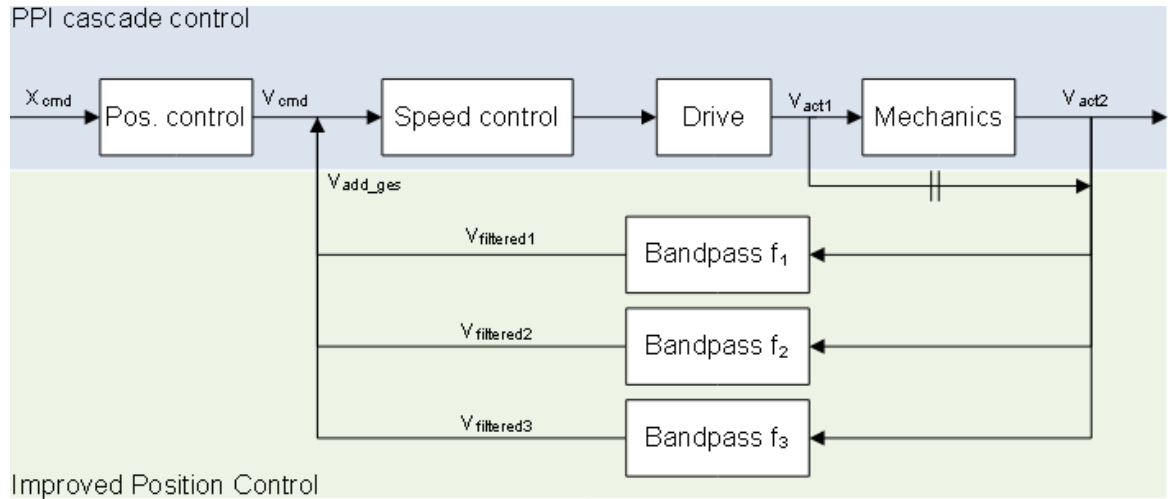

**Fig. 1: Extension of the cascade rule for "DIRECT" mode**

Ideally, frequencies to be damped are included in speed values from  $v_{ist2}$  and are recorded by a direct measuring system. The measured frequency range is reduced to the relevant frequency by using a suitable band-pass filter. After scaling the results, an additional additive speed ( $v_{add\_ges}$ ) is added to the manipulated variable of the position controller ( $v_{soll}$ ). This results in a counter-motion of the motor to compensate for a particular vibration.

If no direct measuring system is installed, the actual values of the motor ( $v_{ist1}$ ) can be used as an alternative, provided the vibration is visible in the actual speed of the motor encoder ( $v_{ist1}$ ).



### Attention

**Excessive scaling of the additive speed may cause the motor to vibrate.**

Consequence: The control loop becomes unstable.

## 2.2 "INDIRECT" mode

"INDIRECT" mode (P-AXIS-00753 [▶ 17]) can be used if the measuring system does not include the vibration to be damped (P-AXIS-00751 [▶ 16]). The mechanical vibration is simulated by a digital filter:

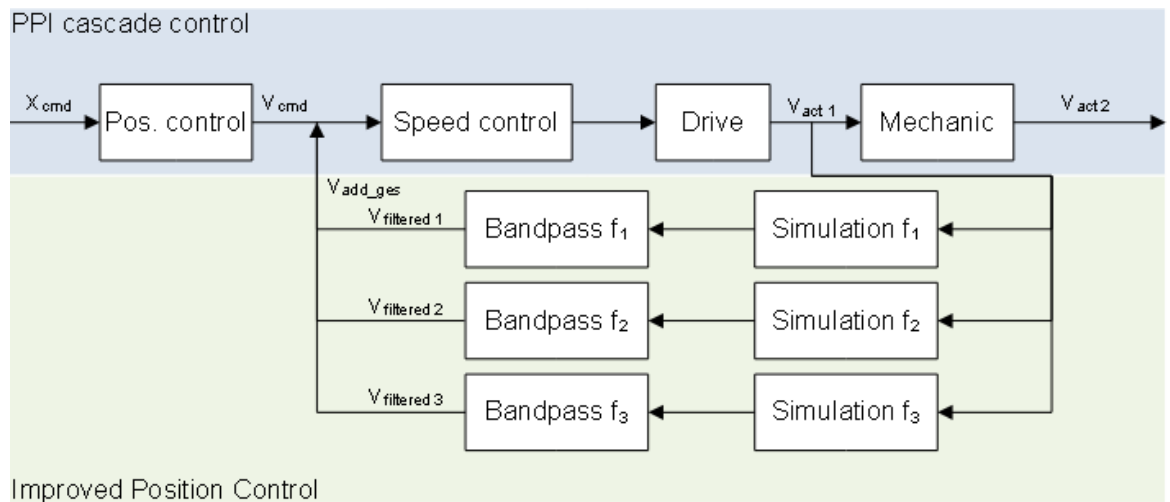

**Fig. 2: Extension of the cascade rule for "INDIRECT" mode**

A simulation of the mechanical vibration can be executed by specifying a separate damping ratio (P-AXIS-00756 [▶ 19]) for each of the frequencies to be damped. The simulation results are handled in the same way as the results from measurements taken from a direct measuring system. The frequency range is reduced to the relevant frequency by using a suitable band-pass filter. After weighting the results, an additive speed is added to the manipulated variable causing a counter-motion of the motor to compensate for the vibration.

### Advantage of "INDIRECT" mode

Compared to \*DIRECT" mode, "INDIRECT" mode offers the advantage of producing strong excitation in the simulation, even for weak vibrations that are not visible in the motor actual values or from the direct measuring system. This allows the "Improved Position Control" function to damp vibrations that are not suitable for \*DIRECT" mode.



#### Attention

**Excessive scaling of the additive speed may cause the motor to vibrate.**

Consequence: The control loop becomes unstable.



#### Attention

**At high frequencies, a phase shift of the output additive speed may occur due to the dead time of the simulation.**

Consequence: Vibrations may be intensified instead of being damped.



#### Attention

**Low damping ratios may cause the output of high additive speeds.**

Consequence: The drive may be excited to vibrate.



## 2.3 "SET\_POINT" mode

"SET\_POINT" mode (P-AXIS-00753 [▶ 17]) is based on the same principle as "INDIRECT" mode.

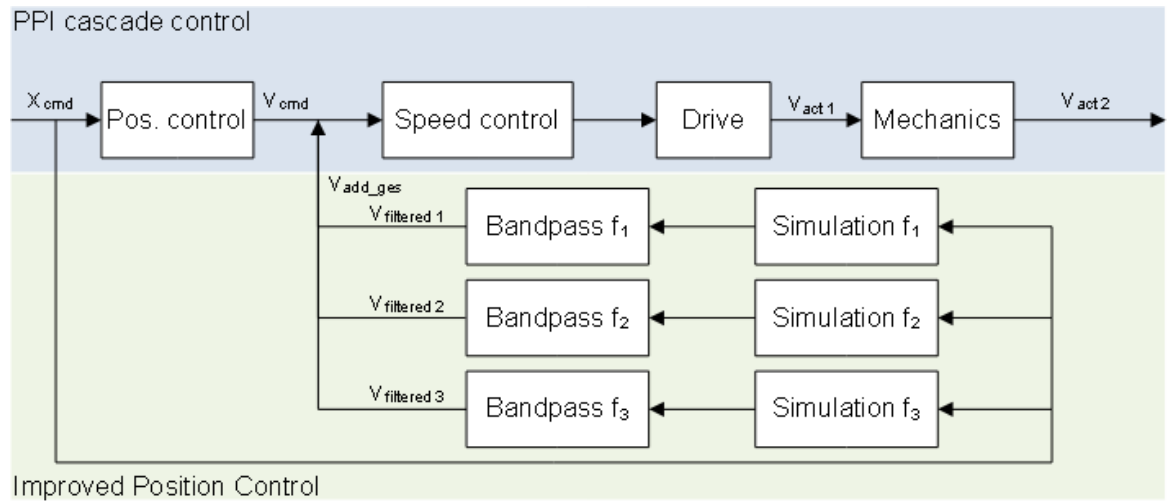

Fig. 3: "SET\_POINT" mode

As you can see in the figure above, mechanical vibration is also simulated in "SET\_POINT" mode. The difference between this mode and "INDIRECT" mode lies in the values on which the simulation is based:

"SET\_POINT" mode uses the command speeds from the position controller directly. This avoids the dead time caused by the measurement and transfer of the actual speed.

### Advantage of "SET\_POINT" mode

The output additive speed values are therefore somewhat faster than in "INDIRECT" mode. As a result, the phase shift plays a minor role and higher frequencies can be damped.

Another advantage of "SET\_POINT" mode is that the drive is not excited to vibrate due to feedback of the actual values. On the downside, information that "INDIRECT" mode obtains by using the actual values of the motor is lost.



#### Attention

**At high frequencies, a phase shift of the output additive speed may occur due to the dead time of the simulation.**

Consequence: Vibrations may be intensified instead of being damped.



#### Attention

**Low damping ratios may cause the output of high additive speeds.**

Consequence: The drive may be excited to vibrate.

### 3 Enabling

As parameterising the "Improved Position Control" function is critical for system stability, the subsections below contain information on enabling the function.

#### 3.1 Prerequisites

Please observe the following when using "Improved Position Control":

- The axis must be in the position control (CNC or drive).
- For drives with internal position control, the "Improved Position Control" function is output by an additive speed. You must therefore configure this in the process data. The section below deals with the configuration for CANopen. For SERCOS, you must also configure the S-0-0037 parameter. Carry out scaling for the speed interface correctly by using the parameters P-AXIS-00205 [▶ 21], P-AXIS-00206 [▶ 22] and P-AXIS-00207 [▶ 22].
- If the axis exists in the CNC position control, the additive speed is directly included in the manipulated variable. Scaling takes place using the scaling factor of the drive manipulated variable P-AXIS-00128 [▶ 20] and P-AXIS-00129 [▶ 21].
- When you carry out an update of changed axis parameters for the "Improved Position Control" function, the axis must be at standstill.

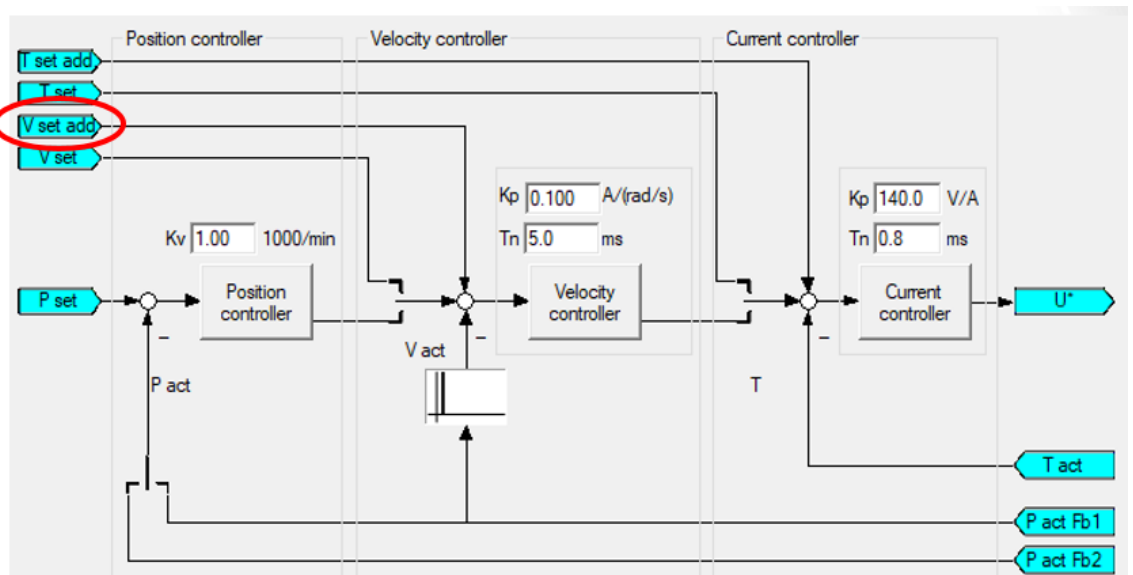

Fig. 4: Representation of additive speed

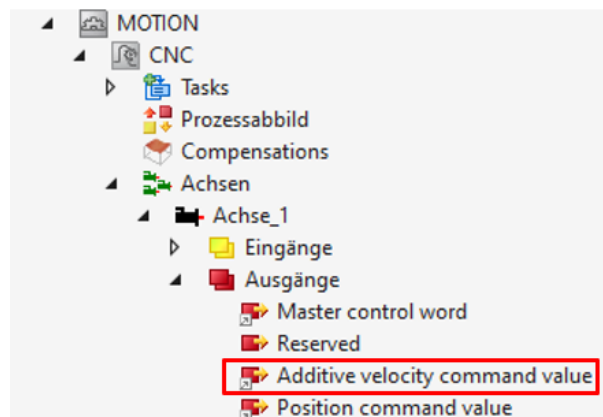

Fig. 5: Additive speed configured for CANopen

### 3.2 Gantry axes

The "Improved Position Control" function allows the damping of vibrations in hard gantry systems.

Enter the parameters in the master axis. Do not enable the function for slave axes in the gantry combination. If the function is enabled in the slave axis, an error with ID 70600 is output.

The additive speed for gantry slave axes is included internally in the master axis parameters.

When the calculated values are output via the additive command speed (position control in the drive), make sure you carry out the scaling of the speed interface for master and slave axes correctly using the parameters

P-AXIS-00205 [▶ 21],

P-AXIS-00206 [▶ 22] and

P-AXIS-00207 [▶ 22]

. Normally, the scaling of the master axis is identical to the scaling of the slave axis.

### 3.3 Application example

The example below shows the results and parameterisation of the "Improved Position Control" function in an application with a toothed rack and pinion drive.

For trial purposes, the axis was moved forward and backward and vibrations were recorded using an acceleration sensor.

53Hz Oscillation while driving

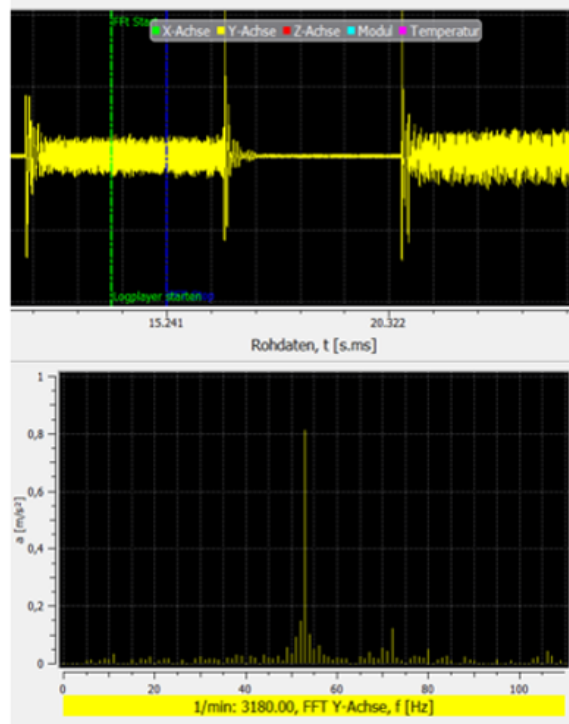

11Hz Oscillation during accelerating/braking

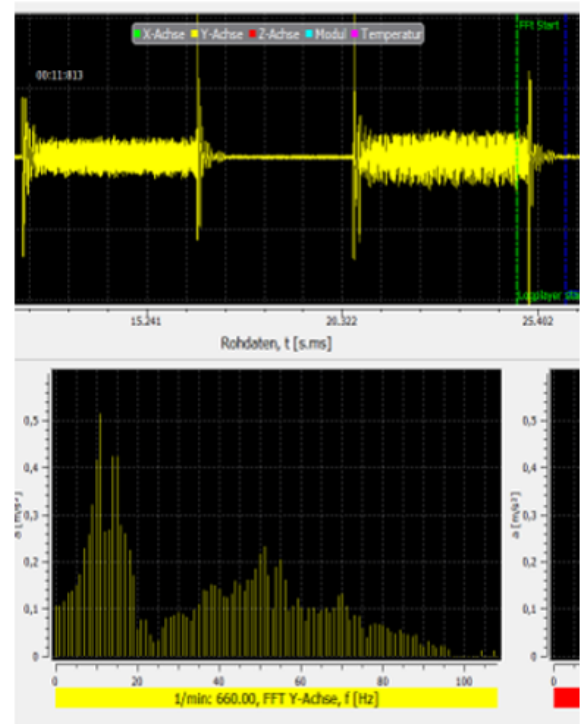

**Fig. 6: Predominant vibrations without Improved Position Control**

The figure above shows the recorded time range in the upper section and the frequency range in the lower section.

During the process, the axis shows a predominant vibration at a frequency of 53Hz and a predominant vibration at 11Hz during acceleration and deceleration. The task is to damp the two frequencies by using the "Improved Position Control" function.

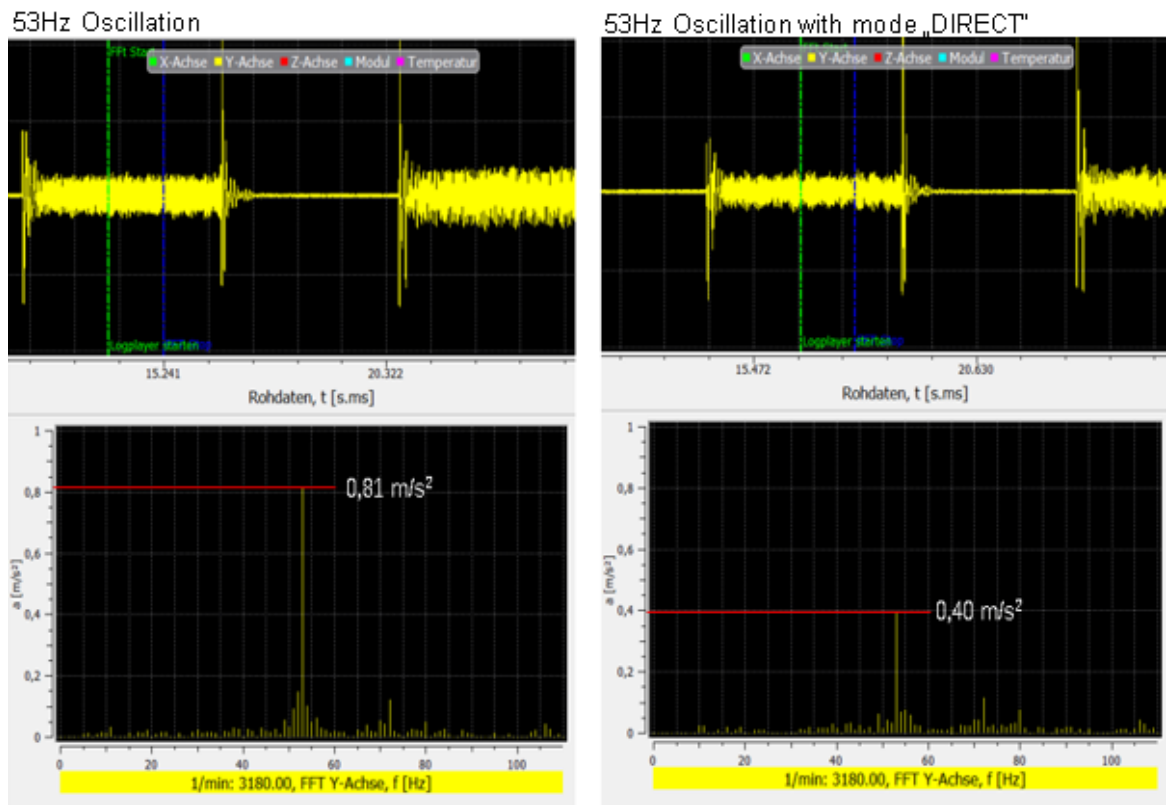
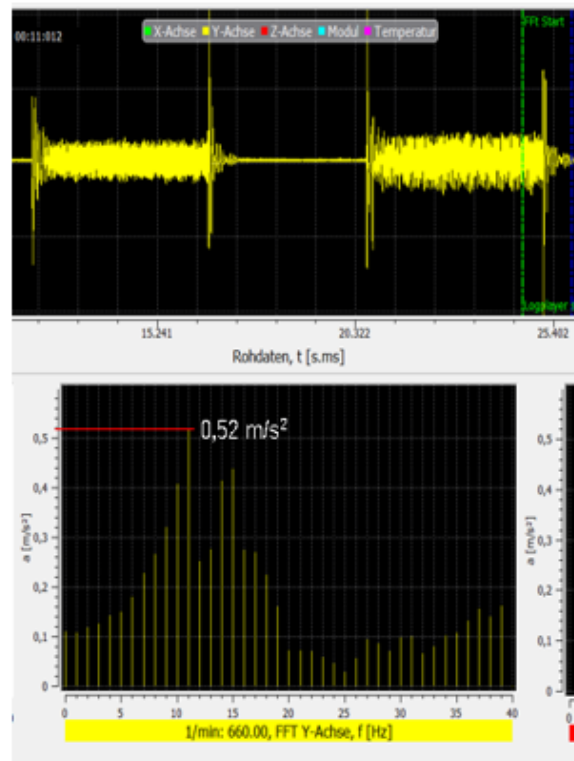

**Fig. 7: Vibration at 53Hz damped by using the “DIRECT” mode.**

The figure above shows vibration damping at 53Hz. The amplitude of  $0.81\text{m/s}^2$  is damped to  $0.40\text{ m/s}^2$  by optimising the “DIRECT” mode parameters.

At the same time, the vibration at 11 Hz is damped by using the "INDIRECT" mode.

11Hz Oscillation



11Hz Oscillation with mode „INDIRECT“

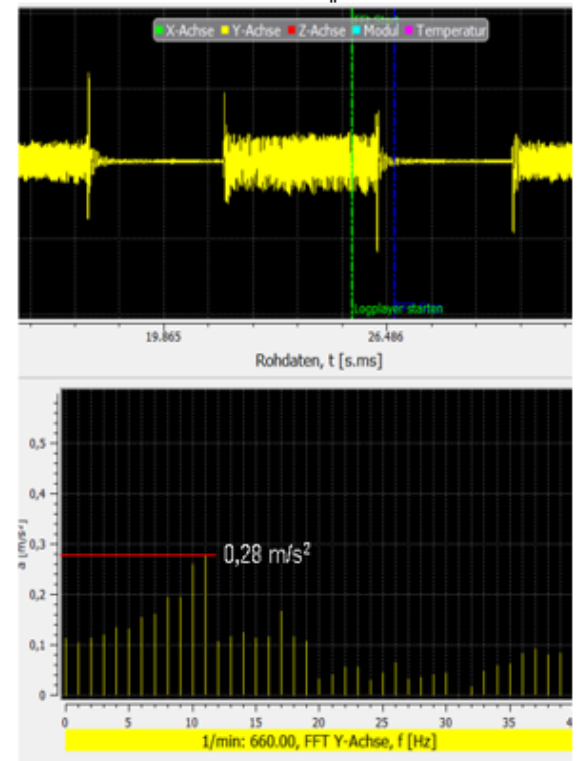

**Fig. 8: Vibration at 11 Hz damped by the "INDIRECT" mode.**

The amplitude is also damped from 0.52 m/s<sup>2</sup> to 0.28 m/s<sup>2</sup> at this frequency by optimising the parameters.

## Parameters used

```

lr_param.improved_position_control.enable           TRUE
lr_param.improved_position_control.v_add_max_fact  1000

lr_param.improved_position_control.stage[0].mode    DIRECT
lr_param.improved_position_control.stage[0].filter.order  2
lr_param.improved_position_control.stage[0].filter.fg_f0  53
lr_param.improved_position_control.stage[0].filter.q_factor  10
lr_param.improved_position_control.stage[0].filter.damping  0.9
lr_param.improved_position_control.stage[0].weight_fact_num  100
lr_param.improved_position_control.stage[0].weight_fact_denom  200

lr_param.improved_position_control.stage[1].mode    INDIRECT
lr_param.improved_position_control.stage[1].filter.order  2
lr_param.improved_position_control.stage[1].filter.fg_f0  90
lr_param.improved_position_control.stage[1].filter.q_factor  10
lr_param.improved_position_control.stage[1].filter.damping  0.5
lr_param.improved_position_control.stage[1].weight_fact_num  100
lr_param.improved_position_control.stage[1].weight_fact_denom  200

lr_param.improved_position_control.stage[2].mode    NOT_ACTIVE
lr_param.improved_position_control.stage[2].filter.order  2
lr_param.improved_position_control.stage[2].filter.fg_f0  90
lr_param.improved_position_control.stage[2].filter.q_factor  10
lr_param.improved_position_control.stage[2].filter.damping  0.4
lr_param.improved_position_control.stage[2].weight_fact_num  100
    
```

```
lr_param.improved_position_control.stage[2].weight_fact_denom 200
```

---

## Procedure explained by example

---

First enable and observe the modes for the frequencies separately to find the best possible parameters for a frequency.

Select the "DIRECT" mode for the frequency at 53 Hz since the frequency is clearly visible in the drive actual values. Due to the high frequency, the quality factor can be increased accordingly. A quality factor of 10 corresponds to a bandwidth of 5.3Hz at this frequency. Then gradually increase the weighting factor until the result deteriorates again.

The same principle is used to determine the parameters for the frequency at 11Hz. Here the "IN-DIRECT" mode is used in order to separate the frequency from its adjacent frequencies. An additional damping must be set for this mode. To determine optimum damping, calculate the damping of the vibration from the time range of the recording. Alternatively, observe the behaviour of the "Improved Position Control" function as you gradually lower the damping.

Finally, activate both frequencies simultaneously and check whether the two stages influence each other. Since both frequencies are relatively far apart in this example, no influence is observable.

## 4 Parameter

The "Improved Position Control" function offers the possibility of damping up to 3 frequencies simultaneously. Certain parameters must be set individually for each of the frequencies to be damped. The frequencies are subdivided during parameterisation in stages (stages[i] where  $0 \leq i \leq 2$ ).



### Notice

**If several frequencies close to each other require damping, take this into account when you set the parameters for each of the stages.**

Consequence: The individual stages may influence each other.

### 4.1 Overview

The following axis parameters are available to adapt the "Improved Position Control" function:

ID	Axis parameter	Description
P-AXIS-00750	order	Order of the filter
P-AXIS-00751	fg_f0	Damped frequency
P-AXIS-00752	q_factor	Filter quality
P-AXIS-00753	mode	Mode
P-AXIS-00754	weight_fact_num	Weighting factor numerator
P-AXIS-00755	weight_fact_denom	Weighting factor denominator
P-AXIS-00756	damping	Filter damping
P-AXIS-00757	v_add_max_fact	Factor for the permissible additive velocity
P-AXIS-00758	enable	Enabling the "Improved Position Control" function

Additional parameters used:

ID	Axis parameter	Description
P-AXIS-00128	multi_gain_n	Adaptation of command value of drive to the drive format (denominator)
P-AXIS-00129	multi_gain_z	Adaptation of command value of drive to the drive format (numerator)
P-AXIS-00205	v_reso_denom	Normalisation of the velocity denominator
P-AXIS-00206	v_reso_num	Normalisation of the velocity numerator
P-AXIS-00207	v_time_base	Normalisation of the velocity numerator

## 4.2 Description

<b>P-AXIS-00750</b>	<b>Order of band-pass filter</b>	
Description	<p>This parameter defines the order of the band-pass filter for all modes (P-AXIS-00753 [► 17]).</p> <p>In addition, this parameter is a value which expresses the fall of frequency response (fall = -order x 20 dB/decade).</p>	
Parameter	lr_param.improved_position_control.stage[i].filter.order	
Data type	UNS32	
Data range	1 <= order <= 3	
Axis types	T, R, S	
Dimension	T: —	R, S: —
Default value	0	
Drive types	SERCOS, Profidrive, CANopen	
Remarks		

<b>P-AXIS-00751</b>	<b>Damped frequency</b>	
Description	<p>The parameter defines the frequency that is to be actively damped by the "Improved Position Control" function.</p> <p>The middle frequency is specified for all modes P-AXIS-00753 [► 17] for the band-pass frequency.</p> <p>For the "INDIRECT" and SET_POINT modes, the simulation of the mechanical vibration is based on the same frequency.</p>	
Parameter	lr_param.improved_position_control.stage[i].filter.fg_f0	
Data type	REAL64	
Data range	0.0 < fg_f0 <= 500.0	
Axis types	T, R, S	
Dimension	T: Hz	R, S: Hz
Default value	-1	
Drive types	SERCOS, Profidrive, CANopen	
Remarks	<p>The "Improved Position Control" function achieves the best results when the dominant frequency of the mechanical vibration is precisely met. The measured frequency may deviate from the actual frequency due to measurement inaccuracies. In many cases, the performance of the function can be enhanced by varying the parameter fg_f0 within a narrow range.</p> <p>Parameter available as of CNC Build V3.1.3077.08 and higher</p>	



<b>P-AXIS-00752</b>	<b>Quality factor of the band-pass filter</b>	
Description	Specifies the inverse value of the bandwidth for the band-pass filter for all modes (P-AXIS-00753 [▶ 17]). $P\text{-}AXIS\text{-}00752 = P\text{-}AXIS\text{-}00751 [▶ 16] / \text{bandwidth}$	
Parameter	lr_param.improved_position_control.stage[i].filter.q_factor	
Data type	REAL64	
Data range	1.0 <= q_factor <= 10.0	
Axis types	T, R, S	
Dimension	T: —	R, S: —
Default value	-1	
Drive types	SERCOS, Profidrive, CANopen	
Remarks	A high filter quality limits the bandwidth of the filtering frequencies. To avoid cutting off any relevant frequencies, it is advisable to raise the filter quality step by step. The filter quality is limited by changing the frequency dependent on machine position and mass inertia. Among other things, a higher filter quality leads to improved damping of the required frequency, whereas a lower quality results in a more robust behaviour of frequency damping.  Parameter available as of CNC Build V3.1.3077.08 and higher	

<b>P-AXIS-00753</b>	<b>Mode for the "Improved Position Control" function</b>	
Description	The following modes are provided for the "Improved Position Control" function and they are applicable simultaneously to various stages. <ul style="list-style-type: none"> <li>• NOT_ACTIVE: IPC is not active.</li> <li>• DIRECT: IPC uses direct measured values. Direct measured values can either come from a direct measuring system or originate from a motor encoder as the actual velocity.</li> <li>• INDIRECT: IPC uses values that are based on the simulation of the mechanical vibration by the measured actual motor velocity.</li> <li>• SET_POINT: IPC uses values that are based on the simulation of the mechanical vibration by the command velocity.</li> </ul>	
Parameter	lr_param.improved_position_control.stage[i].mode	
Data type	UNS32	
Data range	0 - NOT_ACTIVE 1 - DIRECT 2 - INDIRECT 3 - SET_POINT	
Axis types	T, R, S	
Dimension	T: —	R, S: —
Default value	0	
Drive types	SERCOS, Profidrive, CANopen	
Remarks	Parameter available as of CNC Build V3.1.3077.08 and higher	

P-AXIS-00754	Weighting factor numerator	
Description	Weighting factor numerator. The weighting is calculated from P-AXIS-00754 and P-AXIS-00755 [▶ 18]: $\text{Weighting factor} = \text{P-AXIS-00754} / \text{P-AXIS-00755} \text{ [▶ 18]}$ The weighting factor affects the output additive velocity per stage. The weighting factor is limited to a maximum value of 7.0. A weighting factor of <1 reduces the output additive velocity. A weighting factor of >1 increases the output additive velocity.	
Parameter	lr_param.improved_position_control.stage[i].weight_fact_num	
Data type	UNS32	
Data range	0 < weight_fact_num < MAX(UNS32)	
Axis types	T, R, S	
Dimension	T: —	R, S: —
Default value	1	
Drive types	SERCOS, Profidrive, CANopen	
Remarks	To ensure the reliable activation of the "Improved Position Control" function, it is advisable to raise the additive velocity slowly via the weighting factor. Parameter available as of CNC Build V3.1.3077.08 and higher	

P-AXIS-00755	Weighting factor denominator	
Description	Weighting factor denominator. The weighting factor is calculated from P-AXIS-00754 [▶ 18] and P-AXIS-00755. $\text{Weighting factor} = \text{P-AXIS-00754} \text{ [▶ 18]} / \text{P-AXIS-00755}$ The weighting factor affects the output additive velocity per stage. The weighting factor is limited to a maximum value of 7.0. A weighting factor of <1 reduces the output additive velocity; a weighting factor of >1 increases the output additive velocity.	
Parameter	lr_param.improved_position_control.stage[i].weight_fact_denom	
Data type	UNS32	
Data range	0 < weight_fact_denom < MAX(UNS32)	
Axis types	T, R, S	
Dimension	T: —	R, S: —
Default value	1	
Drive types	SERCOS, Profidrive, CANopen	
Remarks	To ensure the reliable activation of the Improved Position Control function, it is advisable to raise the additive velocity slowly via the weighting factor.	

P-AXIS-00756	Damping the simulated mechanical vibration	
Description	The parameter specifies the damping of the simulated mechanical vibration for the modes (P-AXIS-00753 [▶ 17]) INDIRECT and SET_POINT. The parameter has no influence on the DIRECT mode.	
Parameter	lr_param.improved_position_control.stage[i].filter.damping	
Data type	REAL64	
Data range	0.0 < damping < 1.0	
Axis types	T, R, S	
Dimension	T: —	R, S: —
Default value	-1	
Drive types	SERCOS, Profidrive, CANopen	
Remarks	The lower the damping, the more the simulation of the mechanical vibration and the higher the specified additive velocity. To ensure the reliable start of the "Improved Position Control" function, it is advisable to decrease damping slowly. Parameter available as of CNC Build V3.1.3077.08 and higher	

P-AXIS-00757	Factor for the maximum permissible additive velocity	
Description	This parameter limits the maximum permissible additive velocity of the "Improved Position Control" function. The additive velocity is limited in proportion to the maximum axis velocity. $\text{max. additive velocity} = \text{P-AXIS-00757} / 1000 \times \text{P-AXIS-00212}$ If the additive velocity exceeds the calculated value, the limit value continues to be output as the additive velocity.	
Parameter	lr_param.improved_position_control.v_add_max_fact	
Data type	UNS16	
Data range	0 <= v_add_max_fact <= 2000	
Axis types	T, R, S	
Dimension	T: 0.1%	R, S: 0.1%
Default value	0	
Drive types	SERCOS, Profidrive, CANopen	
Remarks	No warning is output if the maximum velocity is exceeded. Parameter available as of CNC Build V3.1.3077.08 and higher	

<b>P-AXIS-00758</b>	<b>Enabling the "Improved Position Control" function</b>	
Description	This parameter enables or disables the "Improved Position Control" function.	
Parameter	lr_param.improved_position_control.enable	
Data type	BOOLEAN	
Data range	0: Improved Position Control is not active 1: Improved Position Control is active	
Axis types	T, R, S	
Dimension	T: ----	R, S: ----
Default value	0	
Drive types	SERCOS, Profidrive, CANopen	
Remarks	Parameter available as of CNC Build V3.1.3077.08 and higher	

<b>P-AXIS-00128</b>	<b>Adapting the drive command value to the drive format (denominator)</b>	
Description	The speed setpoint calculated in the position controller must be adapted to the D/A format of the D/A converter. The digital value at the D/A converter input (getriebe[i].multi_gain_z/ getriebe[i].mult_gain_n) must be specified at which the axis travels at the velocity of [1m/ min] or at the speed [1000°/min]. Numerator: P-AXIS-00129	
Parameter	getriebe[i].multi_gain_n	
Data type	UNS32	
Data range	1 ≤ multi_gain_n ≤ MAX(UNS32)	
Axis types	T, R, S	
Dimension	T: ----	R,S: ----
Default value	1	
Drive types	Simulation, Conventional, Terminal, Lightbus, Profidrive	
Remarks		

P-AXIS-00129	Adaptation of command value of drive to the drive format (numerator)	
Description	The speed setpoint calculated in the position controller must be adapted to the D/A format of the D/A converter. The digital value at the D/A converter input (getriebe[i].multi_gain_z/getriebe[i].mult_gain_n) must be specified at which the axis travels at the velocity of [1m/min] or at the speed [1000°/min]. Denominator : P-AXIS-00128	
Parameter	getriebe[i].multi_gain_z	
Data type	UNS32	
Data range	$1 \leq \text{multi\_gain\_z} \leq \text{MAX}(\text{UNS32})$	
Axis types	T, R, S	
Dimension	T: Bit	R,S: Bit
Default value	2000	
Drive types	Simulation, Conventional, Terminal, Lightbus, Profidrive	
Remarks		

P-AXIS-00205	Normalisation of the velocity (denominator)	
Description	The conversion factor of the set velocity to drive format is obtained by specifying the value output to the drive and the related path distance covered in the time specified in P-AXIS-00207. This parameter specifies the conversion factor numerator. (P-AXIS-00206 is the numerator) This parameter indicates the path covered in the time specified in P-AXIS-00207, provided the value in P-AXIS-00206 is output to the drive. The path is specified in 1 µm or 0.001°.	
Parameter	antr.v_reso_denom	
Data type	UNS32	
Data range	$1 \leq \text{v\_reso\_denom} \leq \text{MAX}(\text{UNS32})$	
Axis types	T, R, S	
Dimension	T: 1µm	R,S: 0,001°
Default value	36	
Drive types	All drive types	
Remarks		

<b>P-AXIS-00206</b>	<b>Normalisation of command velocity (numerator)</b>	
Description	<p>The conversion factor of the command velocity to drive format is defined by specifying the value output to the drive and the related distance covered in the time specified in P-AXIS-00207 .</p> <p>This parameter specifies the conversion factor numerator. (P-AXIS-00205 is the denominator)</p> <p>The factor indicates the number of velocity increments output.</p>	
Parameter	antr.v_reso_num	
Data type	UNS32	
Data range	$0 \leq v\_reso\_num \leq \text{MAX}(\text{UNS32})$	
Axis types	T, R, S	
Dimension	T: increments	R,S: increments
Default value	1	
Drive types	All drive types	
Remarks		

<b>P-AXIS-00207</b>	<b>Time base for normalisation of velocity</b>	
Description	<p>The time base for adapting the velocity interface to the unit used in the drive can be specified as value per minute, second or sampling interval. If normalisation per sampling interval is selected, the output value changes proportionally depending on the CNC cycle time at constant velocity. This may be essential depending on the drive.</p>	
Parameter	antr.v_time_base	
Data type	UNS16	
Data range	0: per minute 1: per second 2: per sampling interval	
Axis types	T, R, S	
Dimension	T: ----	R,S: ----
Default value	0	
Drive types	SERCOS	
Remarks		

## 5 Appendix

### 5.1 Suggestions, corrections and the latest documentation

Did you find any errors? Do you have any suggestions or constructive criticism? Then please contact us at [documentation@isg-stuttgart.de](mailto:documentation@isg-stuttgart.de). The latest documentation is posted in our Online Help (DE/EN):



QR code link: <https://www.isg-stuttgart.de/documentation-kernel/>

The link above forwards you to:

<https://www.isg-stuttgart.de/fileadmin/kernel/kernel-html/index.html>



#### Notice

##### Change options for favourite links in your browser;

Technical changes to the website layout concerning folder paths or a change in the HTML framework and therefore the link structure cannot be excluded.

We recommend you to save the above "QR code link" as your primary favourite link.

##### PDFs for download:

DE:

<https://www.isg-stuttgart.de/produkte/softwareprodukte/isg-kernel/dokumente-und-downloads>

EN:

<https://www.isg-stuttgart.de/en/products/softwareproducts/isg-kernel/documents-and-downloads>

**E-Mail:** [documentation@isg-stuttgart.de](mailto:documentation@isg-stuttgart.de)

## Keyword index

### P

---

P-AXIS-00128 .....	20
P-AXIS-00129 .....	21
P-AXIS-00205 .....	21
P-AXIS-00206 .....	22
P-AXIS-00207 .....	22
P-AXIS-00750 .....	16
P-AXIS-00751 .....	16
P-AXIS-00752 .....	17
P-AXIS-00753 .....	17
P-AXIS-00754 .....	18
P-AXIS-00755 .....	18
P-AXIS-00756 .....	19
P-AXIS-00757 .....	19
P-AXIS-00758 .....	20





© Copyright  
ISG Industrielle Steuerungstechnik GmbH  
STEP, Gropiusplatz 10  
D-70563 Stuttgart  
All rights reserved  
[www.isg-stuttgart.de](http://www.isg-stuttgart.de)  
[support@isg-stuttgart.de](mailto:support@isg-stuttgart.de)

