



# DOCUMENTATION ISG-kernel

## Functional description Jog of path

Short Description:  
FCT-C15

# Preface

## Legal information

---

This documentation was produced with utmost care. The products and scope of functions described are under continuous development. We reserve the right to revise and amend the documentation at any time and without prior notice.

No claims may be made for products which have already been delivered if such claims are based on the specifications, figures and descriptions contained in this documentation.

## Personnel qualifications

---

This description is solely intended for skilled technicians who were trained in control, automation and drive systems and who are familiar with the applicable standards, the relevant documentation and the machining application.

It is absolutely vital to refer to this documentation, the instructions below and the explanations to carry out installation and commissioning work. Skilled technicians are under the obligation to use the documentation duly published for every installation and commissioning operation.

Skilled technicians must ensure that the application or use of the products described fulfil all safety requirements including all applicable laws, regulations, provisions and standards.

## Further information

---

Links below (DE)

<https://www.isg-stuttgart.de/produkte/softwareprodukte/isg-kernel/dokumente-und-downloads>

or (EN)

<https://www.isg-stuttgart.de/en/products/softwareproducts/isg-kernel/documents-and-downloads>

contains further information on messages generated in the NC kernel, online help, PLC libraries, tools, etc. in addition to the current documentation.

## Disclaimer

---

It is forbidden to make any changes to the software configuration which are not contained in the options described in this documentation.

## Trade marks and patents

---

The name ISG®, ISG kernel®, ISG virtuos®, ISG dirigent® and the associated logos are registered and licensed trade marks of ISG Industrielle Steuerungstechnik GmbH.

The use of other trade marks or logos contained in this documentation by third parties may result in a violation of the rights of the respective trade mark owners.

## Copyright

---

© ISG Industrielle Steuerungstechnik GmbH, Stuttgart, Germany.

No parts of this document may be reproduced, transmitted or exploited in any form without prior consent. Non-compliance may result in liability for damages. All rights reserved with regard to the registration of patents, utility models or industrial designs.

# General and safety instructions

## Icons used and their meanings

This documentation uses the following icons next to the safety instruction and the associated text. Please read the (safety) instructions carefully and comply with them at all times.

## Icons in explanatory text

➤ Indicates an action.

⇒ Indicates an action statement.



### **DANGER**

#### **Acute danger to life!**

If you fail to comply with the safety instruction next to this icon, there is immediate danger to human life and health.



### **CAUTION**

#### **Personal injury and damage to machines!**

If you fail to comply with the safety instruction next to this icon, it may result in personal injury or damage to machines.



### **Attention**

#### **Restriction or error**

This icon describes restrictions or warns of errors.



### **Notice**

#### **Tips and other notes**

This icon indicates information to assist in general understanding or to provide additional information.



### **Example**

#### **General example**

Example that clarifies the text.



### **Programming Example**

#### **NC programming example**

Programming example (complete NC program or program sequence) of the described function or NC command.



### **Release Note**

#### **Specific version information**

Optional or restricted function. The availability of this function depends on the configuration and the scope of the version.

# Table of contents

<b>Preface</b> .....	<b>2</b>
<b>General and safety instructions</b> .....	<b>3</b>
<b>1 Overview</b> .....	<b>6</b>
<b>2 Description</b> .....	<b>7</b>
2.1 Configuring axes and channels.....	9
2.2 Switchover sequence.....	12
2.3 Positions off set.....	13
2.4 Application examples.....	15
<b>3 PLC interface</b> .....	<b>16</b>
3.1 PLC example code for CNC Builds as of V2.11.20xx.....	17
<b>4 HMI interface</b> .....	<b>19</b>
<b>5 Parameter</b> .....	<b>20</b>
5.1 Overview.....	20
5.2 Description.....	20
5.3 CNC objects.....	23
<b>6 Appendix</b> .....	<b>24</b>
6.1 Suggestions, corrections and the latest documentation.....	24
<b>Keyword index</b> .....	<b>25</b>

## List of figures

Fig. 1:	Moving axes by different channels .....	7
Fig. 2:	Configuring axes.....	10
Fig. 3:	Initialising a cloned axis .....	11
Fig. 4:	Handshake between axes when access to a channel axis is suspended .....	12
Fig. 5:	Position offset by another channel .....	13
Fig. 6:	Position sequence of the example.....	15
Fig. 7:	Waiting for axis acknowledgement.....	19

# 1 Overview

## Task

---

This function permits a pause in the machining process to be made in a channel and to move the same physical axes from a second channel.

This is referred to as a channel switchover.

## Properties

---

Switching over a channel to react to events which require any path motion, e.g. changing a torch in a flame or gas cutting operation.

## Parameter

---

An auxiliary channel is required here; it must contain the parameters [▶ 9] for the auxiliary axes.

## ***Mandatory note on references to other documents***

---

For the sake of clarity, links to other documents and parameters are abbreviated, e.g. [PROG] for the Programming Manual or P-AXIS-00001 for an axis parameter.

For technical reasons, these links only function in the Online Help (HTML5, CHM) but not in pdf files since pdfs do not support cross-linking.

## 2 Description

### Request

The user has the frequent request to interrupt a running program in order to insert a path motion and then continue the program after the interruption.

Inserting a path motion can be implemented by using an “auxiliary channel”. In this document, an “auxiliary channel” is referred to as a **jog-of-path channel**.

A **jog-of-path channel** contains linked axes which are connected to the same physical axes as the axes in the actual channel.

### Switchover

Channels are switched over by the PLC. Exclusive access of a channel to physical axes is controlled by a control unit provided for each channel.

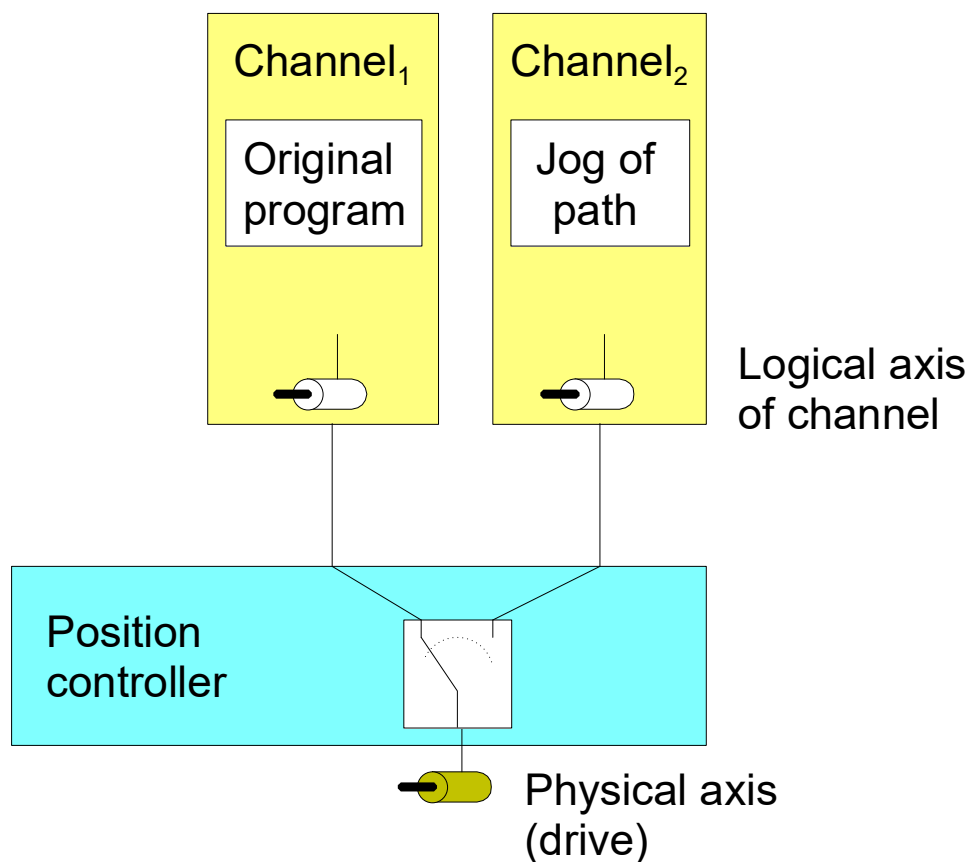

Fig. 1: Moving axes by different channels

### Position offset

When an axis is moved by an inserted path motion, it also retains the offset in the original channel as soon as this channel regains access to the axis.

If this is not required, the user must ensure that the axes are returned to the position they were in before the interruption.



### Notice

#### Licensing note

No additional channel license is required for jog-of-path channels containing only axes which are linked to physical axes of other channels.

The parameter P-CHAN-00306 [▶ 20] must be set for this purpose.



### Notice

**Suspending axes is not possible when a channel is in error state, for example, due to a programming error or a channel axis error.**

Before suspending the channel axes, remove the error state and reset the channel.



## 2.1 Configuring axes and channels

### Axes

In order to interrupt a machining process and move an axis by another channel, an additional logical axis (e.g. Log. AchsNr. 11) is configured and linked to an existing physical axis (e.g. Log. AchsNr. 1). The link is specified in the axis parameter `kopf.link_to` (P-AXIS-00101).

A clone operation takes over all data from the original axis except for the new axis number. This is executed by the axis parameter `kopf.clone_of` (P-AXIS-00040) by specifying the axis number of the axis whose axis parameter list is to be copied.

```
kopf.achs_nr           11
kopf.link_to           1
kopf.clone_of           1
```

### Channels

The channels are configured with the logical axes as usual.

Channel 1 contains axes 1 to 3 as the main axes

```
gruppe[0].achs_anzahl      3
gruppe[0].achse[0].log_achs_nr  1
gruppe[0].achse[0].bezeichnung X
gruppe[0].achse[1].log_achs_nr  2
gruppe[0].achse[1].bezeichnung Y
gruppe[0].achse[2].log_achs_nr  3
gruppe[0].achse[2].bezeichnung Z
```

Channel 2 represents the jog-of-path channel and contains axes 11 to 13 as main axes

```
gruppe[0].achs_anzahl      3
gruppe[0].achse[0].log_achs_nr  11
gruppe[0].achse[0].bezeichnung X
gruppe[0].achse[1].log_achs_nr  12
gruppe[0].achse[1].bezeichnung Y
gruppe[0].achse[2].log_achs_nr  13
gruppe[0].achse[2].bezeichnung Z
```

The parameter P-CHAN-00306 [▶ 20] is set in the jog-of-path channel for checking the license.

```
jog_of_path_only          1
```

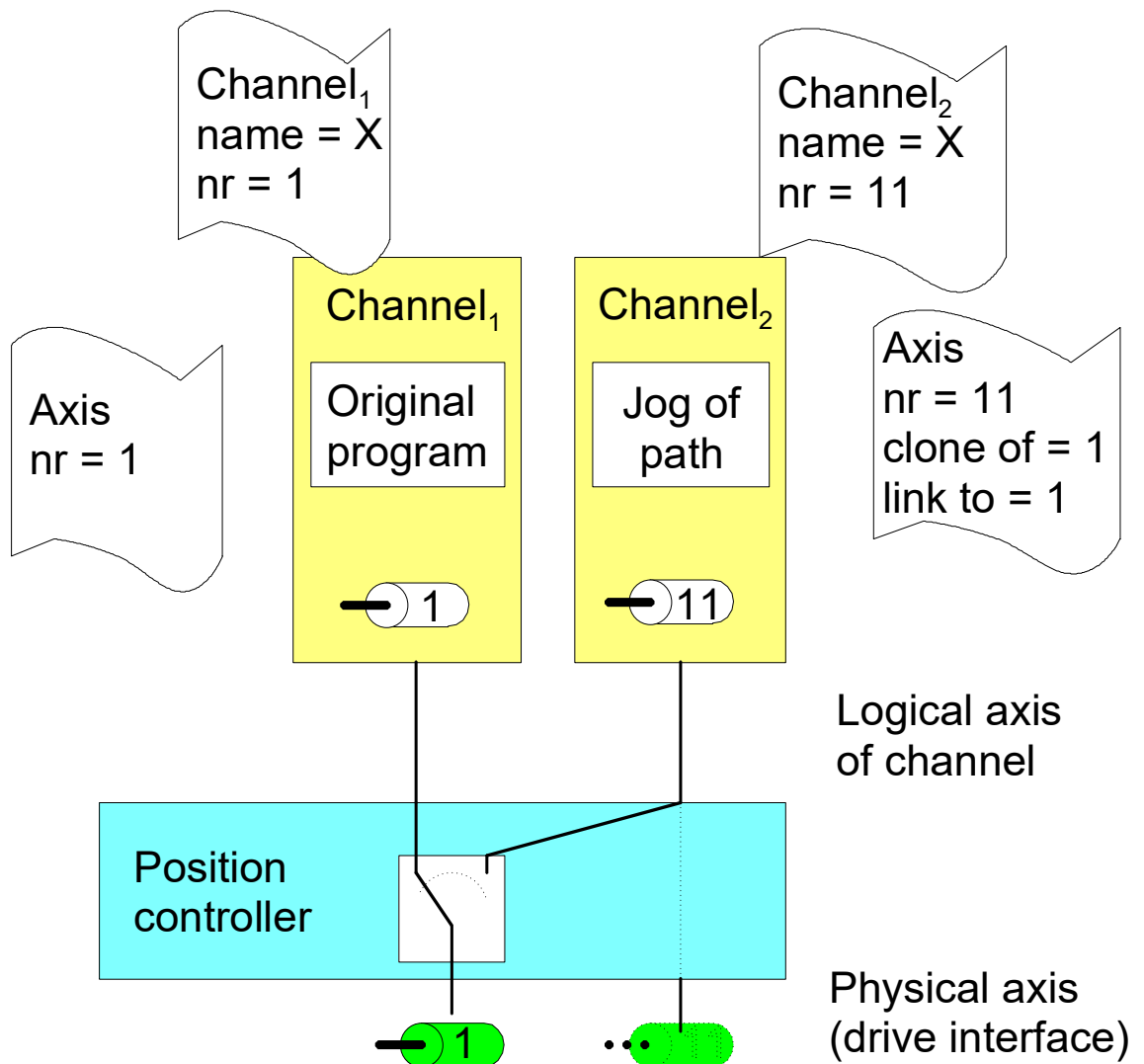

Fig. 2: Configuring axes

## Cloned axis

To create a cloned axis, the axis must first already exist and be initialised before its axis parameter list can be used as a template for the cloned axis. A cloning process involves taking over the parameters of the axis which acts as a template only once. Any subsequent change in axis parameters has no effect on the cloned data set. It only modifies or overwrites the individual axis parameters.



### Notice

#### Spindle programming in the jog-of-path channel

Spindle axes cannot be created as cloned axes. However, as of CNC Build V3.3081.5 or V3.1.3112.0, use of the functions G33, G331 and #CAX is permitted in the jog-of-path channel but this requires a spindle. A default main spindle must therefore be created in the jog-of-path channel. This permits the use of exactly one spindle in conjunction with the functions mentioned above without an additional channel license.

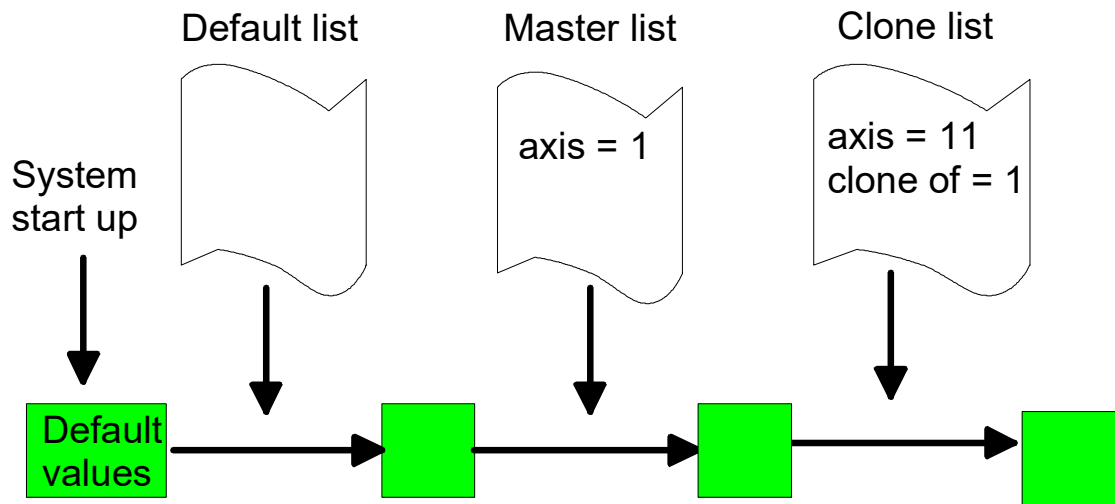

Fig. 3: Initialising a cloned axis



**Notice**

The specified clone reference cannot be changed after the first initialisation.



**Notice**

If the clone has no master axis, the error messages ID 70172 and ID 50462 are output and a cloned axis is created without a real cloning process.

## 2.2 Switchover sequence

### Access to axes

As long as the output of a channel is not suspended, the physical axes are linked to the logical axes of the channel. If a second channel requests the same physical axes as those of the first channel, the system waits automatically until the first channel has suspended its output.

If axes move in the channel which suspends axis access, these axes are stopped by a feedhold triggered internally in the NC kernel.

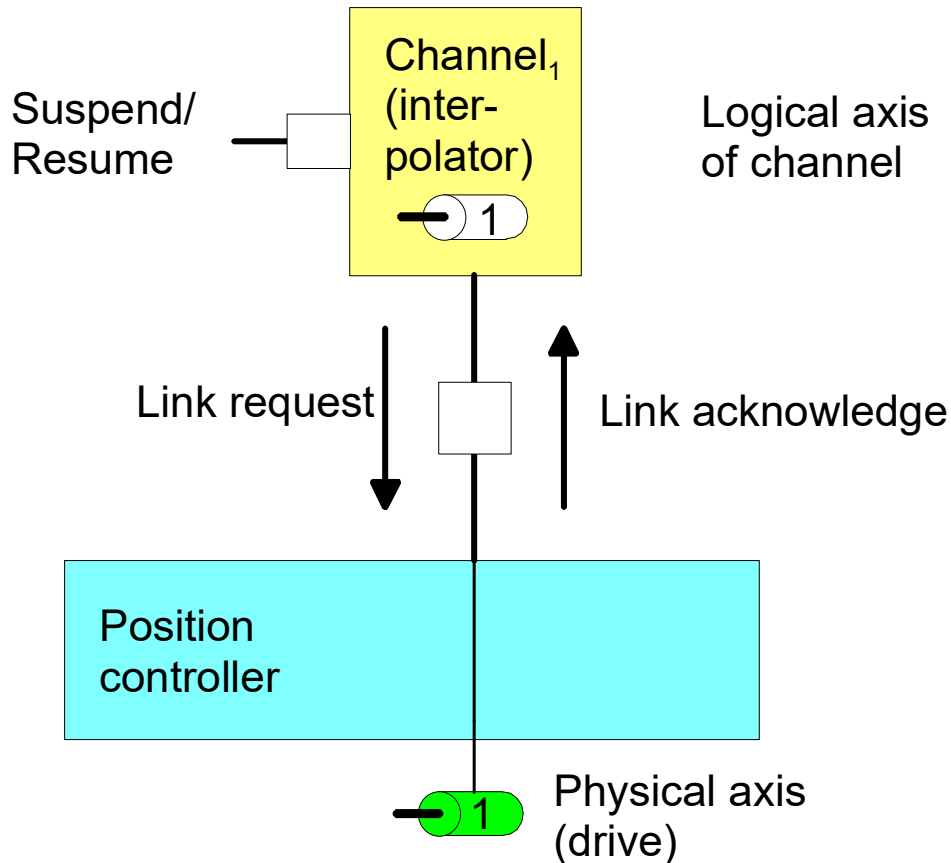

Fig. 4: Handshake between axes when access to a channel axis is suspended



#### Notice

If access to a physical axis is configured by two (or several) channels, one channel is not given access to the axes until all other channels have suspended their access.

## 2.3 Positions off set

The link between a physical and a logical axis can be changed by an active program with the axes at standstill. After axis output is suspended, the axes can be moved by another channel.

After an axis is returned to the original channel, the commanded position in the channel (command position) and the physical position (active position) may be different. This position offset is cleared at program start and with NC commands (such as #CHANNEL INIT[], deselection of G200 etc.) which cause a position adjustment in the channel.

Therefore, the commanded position in the channel corresponds to the physical set position of the axis (command position = active position).



### Notice

The position offsets of the axes are cleared when the channel is initialised or at program start.

Offset = command position (of active link) – active position

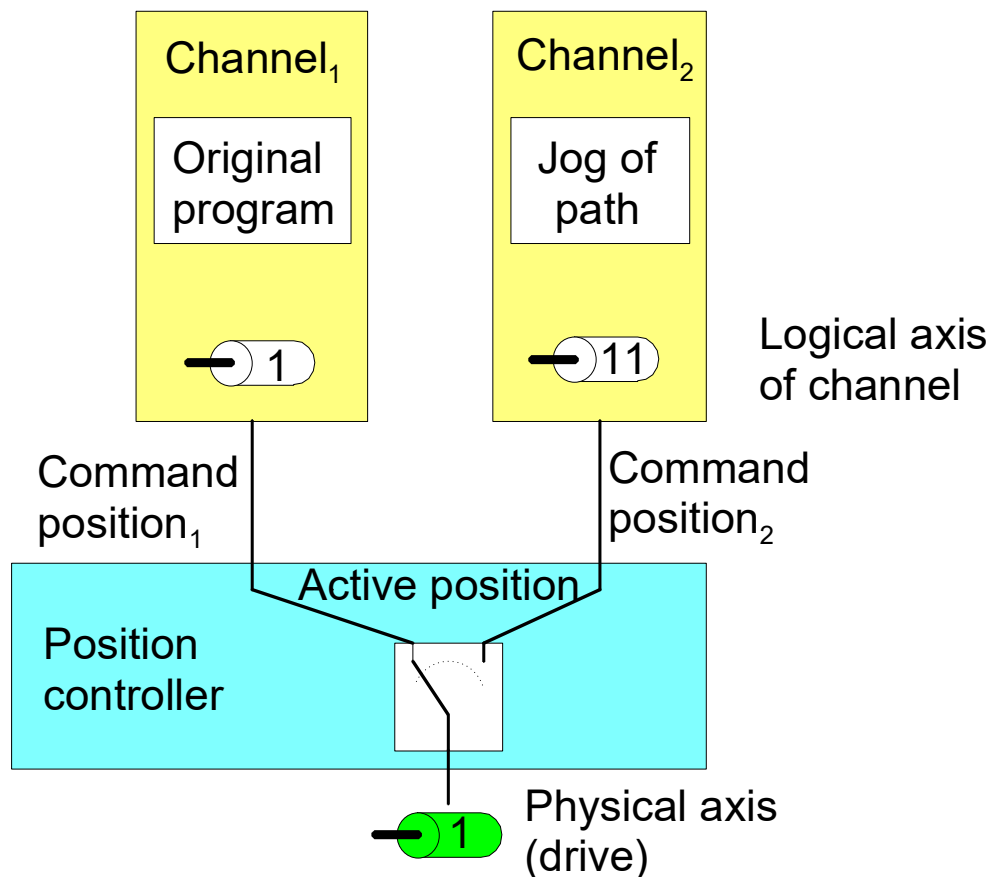

Fig. 5: Position offset by another channel



## Example

### Manual block in both channels

Axis 1 of channel 1 and axis 11 of channel 2 are linked to the same physical axis. In each channel, a different manual block (without M30) is started and the channels are suspended one after another.

Channel 1: Command position (command position)	Channel 2: Command position (command position)	Physical axis posi- tion (active position)	Offset channel 1	Offset channel 2
0 -> 50		0 -> 50	0	0
	50 -> 15	50 -> 15	0	0
50 -> 80		15 -> 45	35	-30
	15 -> 0	45 -> 30	50	-30

## 2.4 Application examples

### configuration

2 channels are configured. In channel 1, the Y axis is configured with log axis no. 2 and in channel 2, the cloned axis is configured with the log. axis no. 11.

Configuration of an additional logical axis 11 for physical axis number 2

```
kopf.achs_nr           11
kopf.link_to           2
kopf.clone_of          2
```

### Actions

1. Start manual block "G01 G90 X20 Y20 F100" in 1.Kanal 1
2. Set "Suspend-Output" in the channel 1 to 1
3. Clear "Suspend-Output" in the other channel 2
4. Start manual block "G91 Y10" in channel 2 and wait until it ends its execution
5. Clear "Suspend-Output" in channel 1
6. Set "Suspend-Output" in channel 2

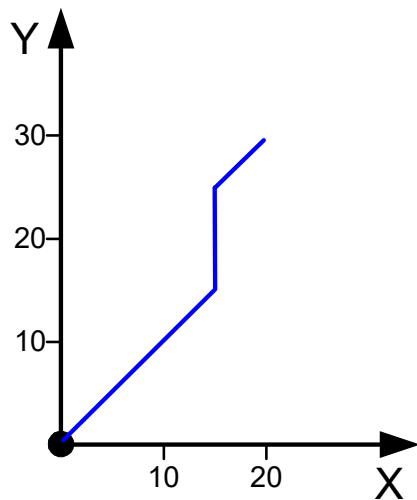

**Fig. 6: Position sequence of the example**

Alternatively, a motion can be started in manual mode in channel 2 instead of the manual block.

### 3 PLC interface

The PLC interface provides control units to switch channel access to the axes and to display the axes.

<b>Interrupt output of command values to real axes</b>	
Description	<p>This interrupts the output of NC channel command values to physical axes. The NC channel is stopped and assignment to the real axes is disabled.</p> <p>Physical axes can then be requested and moved by another channel. A different logical axis can be linked to a physical axis here.</p> <p>After clearing this interruption, the axes can be requested again and the original channel continues its motion.</p>
Data type	MC_CONTROL_BOOL_UNIT, see description Control unit
Access	PLC reads request_r + state_r and writes command_w + enable_w
ST Path	gpCh[channel_idx]^bahn_mc_control.suspend_axis_output
Commanded, requested and return values	
ST Element	<p><b>.command_w</b></p> <p><b>.request_r</b></p> <p><b>.state_r</b></p>
Data type	BOOL
Value range	[TRUE, FALSE]
Redirection	
ST element	<b>.enable_w</b>
<b>Position offset</b>	
Description	<p>Display of the current offset of the absolute position between the position controller axis (real physical axis) and the interpolator axis (logical axis) currently linked in the axis coordinate system.</p> <p>The display here shows an offset between the interpolator position and the position controller position caused by the use of functions such as "jog of path" (see [FCT-C15 [ 6]]).</p> <p>The offset displayed contains no offsets caused by zero offsets, for example.</p>
Signal flow	CNC → PLC
ST path	gpAx[axis_idx]^lr_state. <b>position_offset_r</b>
Data type	DINT
Unit	0.1 μm
Access	PLC is reading



<b>Axis supply</b>	
Description	The command of the physical axes is executed by the logical axis specified in the NC channel.
Signal flow	CNC → PLC
ST path	gpAx[axis_idx]^lr_state.link_to_ipo_r
Data type	UINT
Value range	[= 0 – not linked, > 0 – logical axis number]
Access	PLC is reading

<b>Axis assignment</b>	
Description	The display shows the physical axes to which the commanded values of the logical axes are of the channel output.
Signal flow	CNC → PLC
ST path	gpAx[axis_idx]^ipo_state.link_to_lr
Data type	UINT
Value range	[= 0 – not linked, > 0 – logical axis number]
Access	PLC is reading

### 3.1 PLC example code for CNC Builds as of V2.11.20xx

<b>Interrupt output of command values to real axes</b>	
Description	<p>This interrupts the output of NC channel command values to physical axes. The NC channel is stopped and assignment to the real axes is disabled.</p> <p>Physical axes can then be requested and moved by another channel. A different logical axis can be linked to a physical axis here.</p> <p>After clearing this interruption, the axes can be requested again and the original channel continues its motion.</p>
Data type	MCCControlBoolUnit, see description of Control Unit
Access	PLC reads Request + State and writes Command + Enable
ST Path	pMC[channel_idx]^addr^.MCCControlBahn_Data.MCCControlBoolUnit_SuspendAxisOutput
Commanded, requested and return values	
ST Element	<b>.X_Command</b> <b>.X_Request</b> <b>.X_State</b>
Data type	BOOL
Value range	[TRUE, FALSE]
Redirection	
ST element	<b>.X_Enable</b>

<b>Position offset</b>	
Description	<p>Display of the current offset of the absolute position between the position controller axis (real physical axis) and the interpolator axis (logical axis) currently linked in the axis coordinate system.</p> <p>The display here shows an offset between the position controller position and the interpolator position caused by the use of functions such as "jog of path" (see [FCT-C15 ▶ 6]).</p> <p>The offset displayed contains no offsets caused by zero offsets, for example.</p>
Signal flow	CNC → PLC
ST path	pAC[axis_idx]^addr^.StateLR_Data.D_PositionOffsetPhysicalLogicalACS
Data type	DINT
Value range	0.1 μm
Access	PLC is reading

<b>Axis supply</b>	
Description	The command of the physical axes is executed by the logical axis specified in the NC channel.
Signal flow	CNC → PLC
ST path	pAC[axis_idx]^addr^.StateLR_Data.W_LinkToLogicalAxis
Data type	UINT
Value range	[= 0 – not linked, > 0 – logical axis number]
Access	PLC is reading

<b>Axis assignment</b>	
Description	The display shows the physical axes to which the commanded values of the logical axes are of the channel output.
Signal flow	CNC → PLC
ST path	pAC[axis_idx]^addr^.StateIPO_Data.X_LinkToPhysicalAxis
Data type	UINT
Value range	[= 0 – not linked, > 0 – logical axis number]
Access	PLC is reading

## 4 HMI interface

The current state of an axis can be read by the following channel-specific CNC objects of the axis.

- requested\_link\_to\_physical\_axis
- actual\_link\_to\_physical\_axis [▶ 23]
- link\_state [▶ 23]

In the example below, channel 1 is waiting for the acknowledgement of the request for the second axis. This can be seen by the CNC object “link\_state” which has the value 2.

The command value suppression is not active in either channel.

The screenshot shows the ISG Object Browser interface. The main table displays CNC objects for Channel 1. The 'link\_state' object (No. 25) is highlighted in blue, showing a value of 2. The 'suspend\_axis\_out' object (No. 24) is also highlighted in blue, showing a value of 0. The 'manual cmd. abs. limit.' object (No. 26) is highlighted in red, showing a value of .500.

No	Group	Offset	Name	Value	Unity
21	0x21301	0x20014	ramp time: dec--	30000	µs
22	0x21301	0x20015	rel_sollw_real64	0	0.1 µm/ta
23	0x21301	0x20016	requested_link_to_physical_axis	2	-
24	0x21301	0x20017	actual_link_to_physical_axis	0	-
25	0x21301	0x20018	link_state	2	-
26	0x21301	0x20019	manual cmd. abs. limit.	.500	0.1 µm

Source	Name	Value	Group
GEO > Channels ...	suspend_axis_ou...	0	0x21301
GEO > Channels ...	suspend_axis_ou...	0	0x21302

Fig. 7: Waiting for axis acknowledgement.

## 5 Parameter

### 5.1 Overview

ID	Parameter	Meaning
P-AXIS-00040	kopf.clone_of	Axis copy
P-AXIS-00101	kopf.link_to	Link to the physical axis
P-AXIS-00483	kenngr.auto_re- lease_of_axis_link	Enabling of IPO-LR interface after axis release
P-CHAN-00306	jog_of_path_only	License check of the clone channel

### 5.2 Description

#### Channel parameters

P-CHAN-00306	Checking the license in the clone channel
Description	This parameter checks the license in the clone channel. When this parameter is set, a check is made during start-up whether all the axes configured in the channel are clone axes. Only then is this channel license-free. The check is also made at RESET and axis exchange. If an axis is not a clone axis, an error message is output.
Parameter	jog_of_path_only
Data type	BOOLEAN
Data range	0/1
Dimension	----
Default value	0
Remarks	This parameter allows the 2nd channel to be used as a Jog-Of-Path channel even with a single-channel license. The parameter is available as of Build V3.1.3037.17.

**Axis parameter**

<b>P-AXIS-00040</b>	<b>Mapping of parameters of an existing axis for default configuration.</b>	
Description	For easier configuration, an axis could be a copy (clone) of another axis. This means, when the axis is initialised, the clone just uses the data of its master as template. The clone merely has to specify the differences to its master in the parameter list.	
Parameter	kopf.clone_of	
Data type	UNS16	
Data range	0 < clone_of < MAX(UNS16)	
Axis types	T, R, S	
Dimension	T: ----	R,S: ----
Default value	0	
drive types.	----	
Remarks		
<b>P-AXIS-00101</b>	<b>Linking an interpolator output to a specific physical axis.</b>	
Description	The parameter requests a link between the logical axis of the interpolator and the axis of the position controller (drive). If you attempt to link more than one logical axis to the same drive, all the other axes must wait until this link is temporarily interrupted by a command and released for a new connection.	
Parameter	kopf.link_to	
Data type	UNS16	
Data range	0 < link_to < MAX(UNS16)	
Axis types	T, R, S	
Dimension	T: ----	R,S: ----
Default value	0	
drive types.	----	
Remarks		

P-AXIS-00483	Enabling of IPO-LR interface after axis release	
Description	<p>A drive can be connected as part of the functionality 'Jog of Path' with more than one axis (link_to, P-AXIS-00101). Here the drive is supplied via the axis-specific interface between interpolator and position controller (see [FCT-C15 [▶ 6]]).</p> <p>If this type of linked axis leaves the interpolator after an axis release, and a SUSPEND command is executed in this channel, the interface is not enabled. Another channel that possibly requests this axis has no access to this interface and stops.</p> <p>By setting the parameter 'kenngr.auto_release_of_axis_link' this interface is automatically enabled when the axis is released and a system stop can be avoided.</p>	
Parameter	kenngr.auto_release_of_axis_link	
Data type	BOOLEAN	
Data range	0/1	
Axis types	T, R, S	
Dimension	T: ----	R,S: ----
Default value	0	
drive types.	----	
Remarks		

## 5.3 CNC objects

<b>Name</b>	actual_link_to_physical_axis		
<b>Description</b>	This object shows the currently assigned physical axis. (used for channel switchover)		
<b>Task</b>	GEO (Port 551)		
<b>Index group</b>	0x12130<C <sub>ID</sub> >	<b>Index offset</b>	0x<A <sub>ID</sub> >0017
<b>Data type</b>	UNS16	<b>Length</b>	2
<b>Attributes</b>	read	<b>Unit</b>	[-]
<b>Remarks</b>			

<b>Name</b>	link_state		
<b>Description</b>	This object shows the state of the axis request, i.e. the assignment of logical and physical axes: 0 : Axis link already existing 1 : Physical axis is requested by the position controller 2 : Waiting for acknowledgement of the physical axis from the position controller (used for channel switchover)		
<b>Task</b>	GEO (Port 551)		
<b>Index group</b>	0x12130<C <sub>ID</sub> >	<b>Index offset</b>	0x<A <sub>ID</sub> >0018
<b>Data type</b>	UNS32	<b>Length</b>	4
<b>Attributes</b>	read	<b>Unit</b>	[-]
<b>Remarks</b>			

## 6 Appendix

### 6.1 Suggestions, corrections and the latest documentation

Did you find any errors? Do you have any suggestions or constructive criticism? Then please contact us at [documentation@isg-stuttgart.de](mailto:documentation@isg-stuttgart.de). The latest documentation is posted in our Online Help (DE/EN):



QR code link: <https://www.isg-stuttgart.de/documentation-kernel/>

The link above forwards you to:

<https://www.isg-stuttgart.de/fileadmin/kernel/kernel-html/index.html>



#### Notice

##### Change options for favourite links in your browser;

Technical changes to the website layout concerning folder paths or a change in the HTML framework and therefore the link structure cannot be excluded.

We recommend you to save the above "QR code link" as your primary favourite link.

##### PDFs for download:

DE:

<https://www.isg-stuttgart.de/produkte/softwareprodukte/isg-kernel/dokumente-und-downloads>

EN:

<https://www.isg-stuttgart.de/en/products/softwareproducts/isg-kernel/documents-and-downloads>

**E-Mail:** [documentation@isg-stuttgart.de](mailto:documentation@isg-stuttgart.de)



# Keyword index

## A

---

assignment	
axis	
Axis supply	
axis:logical .....	18
assignment:logical .....	18
physical axis to logical axis .....	18

## O

---

output of command values to real axes	
interrupt .....	16, 17

## P

---

P-AXIS-00040 .....	21
P-AXIS-00101 .....	21
P-AXIS-00483 .....	22
P-CHAN-00306 .....	20
pAC	
Position	
X_LinkToLogicalAxis .....	18
X_LinkToPhysicalAxis .....	18
offset:physical, logical axis .....	16, 18



© Copyright  
ISG Industrielle Steuerungstechnik GmbH  
STEP, Gropiusplatz 10  
D-70563 Stuttgart  
All rights reserved  
[www.isg-stuttgart.de](http://www.isg-stuttgart.de)  
[support@isg-stuttgart.de](mailto:support@isg-stuttgart.de)

