



DOCUMENTATION ISG-kernel

Functional description Spindle

Short Description:
FCT-S1

© Copyright
ISG Industrielle Steuerungstechnik GmbH
STEP, Gropiusplatz 10
D-70563 Stuttgart
All rights reserved
www.isg-stuttgart.de
support@isg-stuttgart.de

Documentation version: 1.05
07/11/2024

Preface

Legal information

This documentation was produced with utmost care. The products and scope of functions described are under continuous development. We reserve the right to revise and amend the documentation at any time and without prior notice.

No claims may be made for products which have already been delivered if such claims are based on the specifications, figures and descriptions contained in this documentation.

Personnel qualifications

This description is solely intended for skilled technicians who were trained in control, automation and drive systems and who are familiar with the applicable standards, the relevant documentation and the machining application.

It is absolutely vital to refer to this documentation, the instructions below and the explanations to carry out installation and commissioning work. Skilled technicians are under the obligation to use the documentation duly published for every installation and commissioning operation.

Skilled technicians must ensure that the application or use of the products described fulfil all safety requirements including all applicable laws, regulations, provisions and standards.

Further information

Links below (DE)

<https://www.isg-stuttgart.de/produkte/softwareprodukte/isg-kernel/dokumente-und-downloads>

or (EN)

<https://www.isg-stuttgart.de/en/products/softwareproducts/isg-kernel/documents-and-downloads>

contains further information on messages generated in the NC kernel, online help, PLC libraries, tools, etc. in addition to the current documentation.

Disclaimer

It is forbidden to make any changes to the software configuration which are not contained in the options described in this documentation.

Trade marks and patents

The name ISG®, ISG kernel®, ISG virtuos®, ISG dirigent® and the associated logos are registered and licensed trade marks of ISG Industrielle Steuerungstechnik GmbH.

The use of other trade marks or logos contained in this documentation by third parties may result in a violation of the rights of the respective trade mark owners.

Copyright

© ISG Industrielle Steuerungstechnik GmbH, Stuttgart, Germany.

No parts of this document may be reproduced, transmitted or exploited in any form without prior consent. Non-compliance may result in liability for damages. All rights reserved with regard to the registration of patents, utility models or industrial designs.

General and safety instructions

Icons used and their meanings

This documentation uses the following icons next to the safety instruction and the associated text. Please read the (safety) instructions carefully and comply with them at all times.

Icons in explanatory text

- Indicates an action.
- ⇒ Indicates an action statement.



DANGER

Acute danger to life!

If you fail to comply with the safety instruction next to this icon, there is immediate danger to human life and health.



CAUTION

Personal injury and damage to machines!

If you fail to comply with the safety instruction next to this icon, it may result in personal injury or damage to machines.



Attention

Restriction or error

This icon describes restrictions or warns of errors.



Notice

Tips and other notes

This icon indicates information to assist in general understanding or to provide additional information.



Example

General example

Example that clarifies the text.



Programming Example

NC programming example

Programming example (complete NC program or program sequence) of the described function or NC command.



Release Note

Specific version information

Optional or restricted function. The availability of this function depends on the configuration and the scope of the version.

Table of contents

Preface	2
General and safety instructions	3
1 Overview	7
2 Description	8
2.1 Control topology	8
2.2 Spindle types.....	10
2.2.1 NC spindle	10
2.2.1.1 Example: Configuring and programming an NC spindle.....	11
2.2.2 PLC spindle.....	12
2.2.2.1 Example: Configuring and programming a PLC spindle.....	13
2.2.2.2 Special application.....	14
2.2.3 Main spindle.....	15
2.2.4 Controlled spindle	16
2.2.4.1 Example: Configuring a sensorless spindle	17
2.2.4.2 Example: Configuring a speed-controlled spindle with speed feedback.....	18
2.2.5 Other configuration examples	19
2.2.5.1 Example: Configuring and programming several spindles	19
2.2.5.2 Example: Configuration of a 2-channel system with 3 spindles.....	21
2.3 Spindle modes	23
2.3.1 Endless rotation	25
2.3.2 Positioning	25
2.3.3 Spindle as channel axis	25
2.4 Spindle behaviour	26
2.4.1 Spindle override	26
2.4.2 Control by CNC.....	26
2.4.3 Behaviour at NC program end or CNC Reset.....	27
2.5 Synchronisation.....	28
2.5.1 M functions.....	29
2.5.2 Spindle speed - path motion	29
2.6 Spindle monitoring	32
2.7 Homing for NC spindles	33
2.8 Spindle functions.....	33
2.8.1 Feed forward.....	33
2.8.2 Gear change	36
2.8.3 Synchronous operation	40
2.8.4 Curve-controlled acceleration	42
2.8.4.1 Method 1: Characteristic curve $a(n)$ in polynomial- or hyperbola form	43
2.8.4.2 Method 2: Characteristic curve for asynchronous drives.....	49
2.8.5 Tool-related dynamic limiting for spindles.....	51
2.8.6 Thread drilling without compensating chuck (G63).....	52
2.8.7 Thread cutting with endlessly rotating spindle (G33).....	54
2.8.8 C-axis machining (face and lateral surface machining)	59
2.8.9 Turning functions	60
2.9 HLI interface objects (NCK PLC interface).....	61

3	Parameter	62
3.1	Overview of channel, axis and tool parameters	62
3.2	Description	65
3.2.1	Channel parameters	65
3.2.2	Axis parameters	76
3.2.3	Tool parameters.....	95
4	Appendix	97
4.1	Suggestions, corrections and the latest documentation.....	97
	Keyword index	98

List of figures

Fig. 1:	Integrating spindles in the NC control topology	8
Fig. 2:	Every NC channel can be configured for access to all available spindles.....	9
Fig. 3:	Operating the NC spindle	10
Fig. 4:	NC spindle with external commanding	11
Fig. 5:	PLC spindle	12
Fig. 6:	Channel-specific commanding of a PLC spindle	14
Fig. 7:	Interfacing the 3 spindles to channel 1	20
Fig. 8:	Interfacing the 3 spindles to channel 1 and channel 2	22
Fig. 9:	State graph of spindle modes for analogue drives	23
Fig. 10:	State graph of spindle modes for digital drives (e.g. SERCOS).....	24
Fig. 11:	Spindle not synchronised with path motion	30
Fig. 12:	Spindle synchronised with path motion	31
Fig. 13:	Define the speed ranges according to the example	38
Fig. 14:	Example of a machine structure for synchronous operation with spindles.....	40
Fig. 15:	Acceleration curve as a function of speed	42
Fig. 16:	Profile of acceleration based on a polynomial or hyperbole	43
Fig. 17:	Acceleration profile based on polynomial or hyperbole with interpolation points	44
Fig. 18:	Curve profile for nominal speed n with polynomials	46
Fig. 19:	Curve profile for nominal speed n with hyperbola	47
Fig. 20:	Acceleration profile with asynchronous drive curve.....	49
Fig. 21:	Curve profile above nominal speed	50
Fig. 22:	Value of thread pitch for longitudinal thread	55
Fig. 23:	Value of thread pitch for tapered thread	55
Fig. 24:	Representation of geometry example.....	56
Fig. 25:	Face and lateral surface machining.....	60

1 Overview

Task

Spindles are machine elements with an electric drive. Their purpose is to engage a tool (milling cutter, drill bit, countersink drill, thread tapping drills, etc.) or a workpiece and set it rotating for the purpose of machining. Spindles are used to machine all types of materials such as metal, wood or plastic. Spindles are also a major component of CNC-controlled machine tools. These machines include lathe or milling machines, machining centres and grinding machines.

Properties

Basically, spindles are distinguished by the different kinds of control. The spindle type can also be determined by its machining task. This document distinguishes between 4 types of spindles:

1. NC spindle
2. PLC spindle
3. Main spindle
4. Controlled spindle

Only spindles which are known to the channel by their configuration can be used in the NC program. This means that a spindle can also be addressed by several channels if it is configured appropriately.

Parameter definition

Depending on its inclusion in the control topology, the type of spindle used and its machining task must be defined as parameters in various configuration data.

- Channel parameters [[▶ 62](#)]
- Axis parameters [[▶ 63](#)]
- Tool parameters [[▶ 64](#)]

Mandatory note on references to other documents

For the sake of clarity, links to other documents and parameters are abbreviated, e.g. [PROG] for the Programming Manual or P-AXIS-00001 for an axis parameter.

For technical reasons, these links only function in the Online Help (HTML5, CHM) but not in pdf files since pdfs do not support cross-linking.

2 Description

2.1 Control topology

The channel parameter list [CHAN] is used to select and parameterise the spindles required for the NC channel from the existing spindles.

Spindles can be commanded via the user interface (NC program or HMI) or via the interface to the PLC (HLI). Depending on the version, 6 - 16 spindles can be commanded per channel in the NC program.

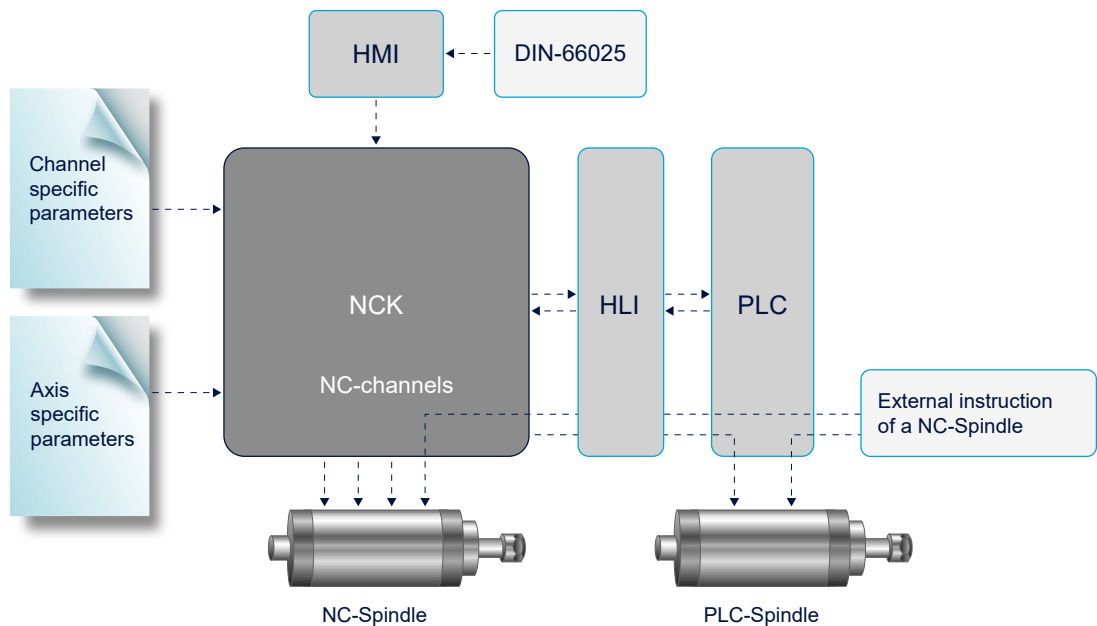

Fig. 1: Integrating spindles in the NC control topology



Release Note

As of CNC Build V3.1.3100, 16 spindles can be commanded per channel.
In CNC Builds up to V3.1.30xx, 6 spindles can be commanded per channel

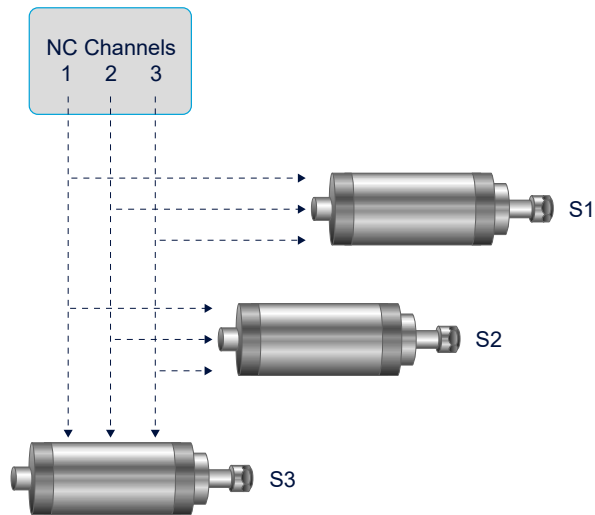

Fig. 2: Every NC channel can be configured for access to all available spindles.

2.2 Spindle types

2.2.1 NC spindle

The NC spindle is operated by a single axis interpolator of the controller.

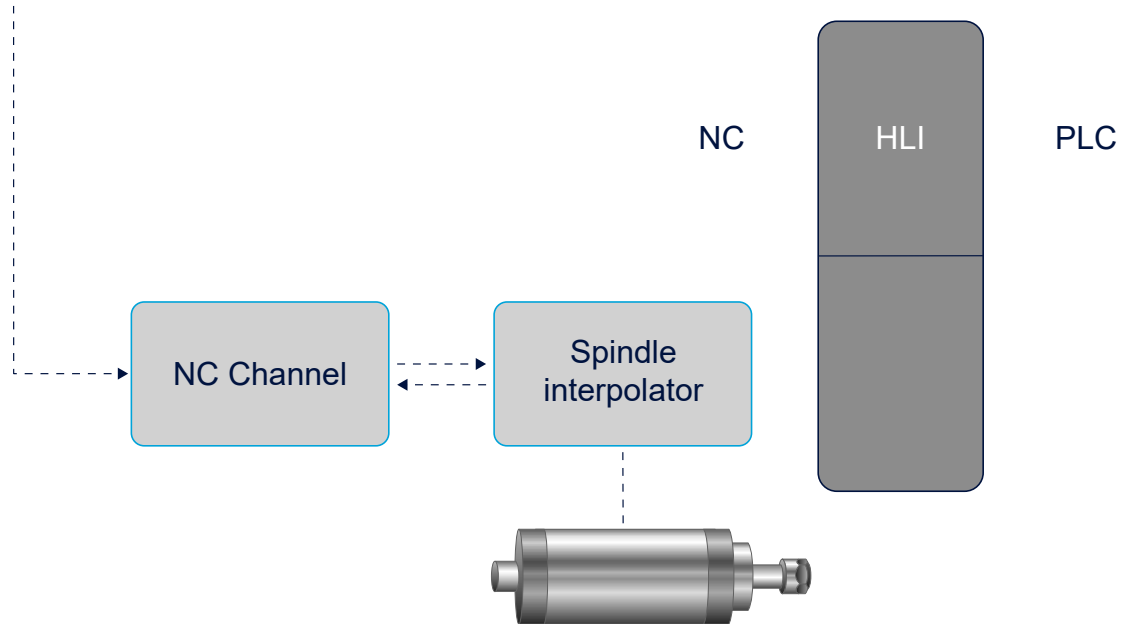

Fig. 3: Operating the NC spindle



Notice

Control with digital drives (e.g. SERCOS) is at the drive end. The speed or torque control modes can also be activated here.

Parameters for the NC spindle

P-AXIS-00015	Operation mode of the axis
P-AXIS-00016	Logical number of the axis
P-AXIS-00018	Type of axis
P-AXIS-00020	Drive type of the axis

P-CHAN-00007	Designation of the spindle
P-CHAN-00036	Logical axis number of the spindle
P-CHAN-00051	Logical axis number of the main spindle
P-CHAN-00053	Designation of the main spindle
P-CHAN-00082	Number of spindles

2.2.1.1 Example: Configuring and programming an NC spindle

Initialisation in the axis parameter list

```
kopf.achs_nr      1
achs_typ         0x0004 Spindel
```

Initialisation in the channel parameter list (channel 1)

```
spdl_anzahl      1
main_spindle_ax_nr  1
main_spindle_name  S

spindel[0].bezeichnung  S1
spindel[0].log_achs_nr  1
```



Programing Example

Configuring and programming an NC spindle

DIN syntax:

```
N10 M03 S1000
N20 Z0
N30 M04 S1000
N40 Z100
N50 M05
N60 M19 S200 S.POS100
M30
```

Axis-specific syntax:

```
N10 S[M03 REV1000]
N20 Z0
N30 S[M04 REV1000]
N40 Z100
N50 S[M05]
N60 S[M19 REV200 POS100]
M30
```

Commanding an NC spindle externally

The NC spindle can be commanded from the PLC process via an additional interface in the HLI.

- The spindle processes the commands sequentially in their order of arrival.
- The PLC process receives the acknowledgements, e.g. about the speed reached.

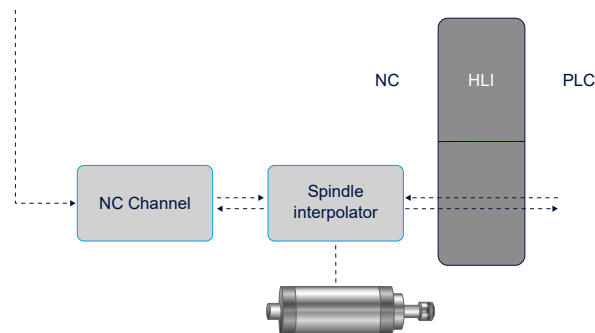

Fig. 4: NC spindle with external commanding

2.2.2

PLC spindle

The PLC spindle is controlled by the PLC.

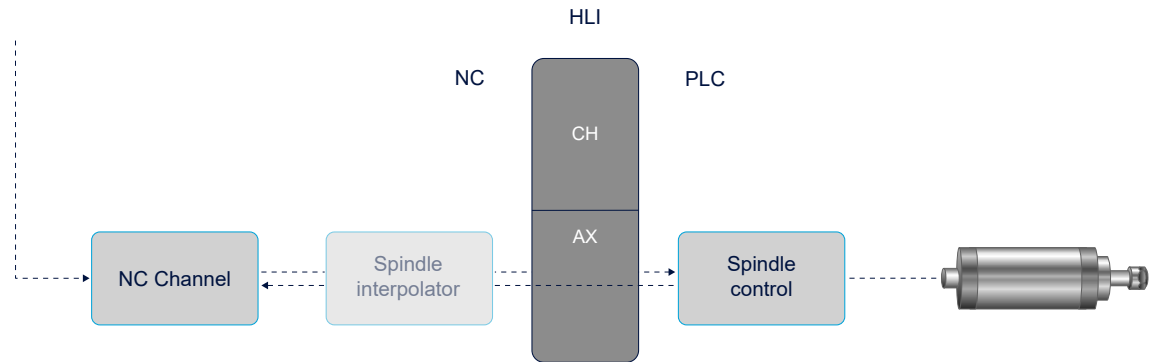

Fig. 5: PLC spindle

The spindle axis is configured and parameterised like an NC spindle. Since no real drive is supplied by the NC, the "simulation" or "virtual" drive type must be selected.

PLC spindles are commanded with speed or position commands by the CNC via the PLC interface (HLI). Control takes place by the PLC. The CNC merely receives an acknowledgement for M functions output to the spindle.

Parameters for the PLC spindle

P-AXIS-00015	Operation mode of the axis
P-AXIS-00016	Logical number of the axis
P-AXIS-00018	Type of axis
P-AXIS-00020	Drive type of the axis

P-CHAN-00007	Designation of the spindle
P-CHAN-00036	Logical axis number of the spindle
P-CHAN-00051	Logical axis number of the main spindle
P-CHAN-00053	Designation of the main spindle
P-CHAN-00082	Number of spindles

2.2.2.1 Example: Configuring and programming a PLC spindle

Initialisation in the axis parameter list

achs_typ	0x00004	Spindel
achs_mode	0x40000	Externally controlled Spindle
antr_typ	0x00004	Simulation

Initialising in the channel parameter list

spdl_anzahl	1
main_spindle_ax_nr	1
main_spindle_name	S
spindel[0].bezeichnung	S1
spindel[0].log_achs_nr	1



Notice

There is no difference between programming NC and PLC spindles.



Programming Example

Configuring and programming a PLC spindle

DIN syntax:

```
N10 M03 S1000
N20 Z0
N30 M04 S1000
N40 Z100
N50 M05
N60 M19 S200 S.POS100
M30
```

Axis-specific syntax:

```
N10 S[M03 REV1000]
N20 Z0
N30 S[M04 REV1000]
N40 Z100
N50 S[M05]
N60 S[M19 REV200 POS100]
M30
```

2.2.2.2 Special application

Data exchange for PLC spindles over the channel-specific HLI range

There is no single axis interpolator for the controller in this configuration. It is possible to command PLC spindles directly by means of the NC channel.

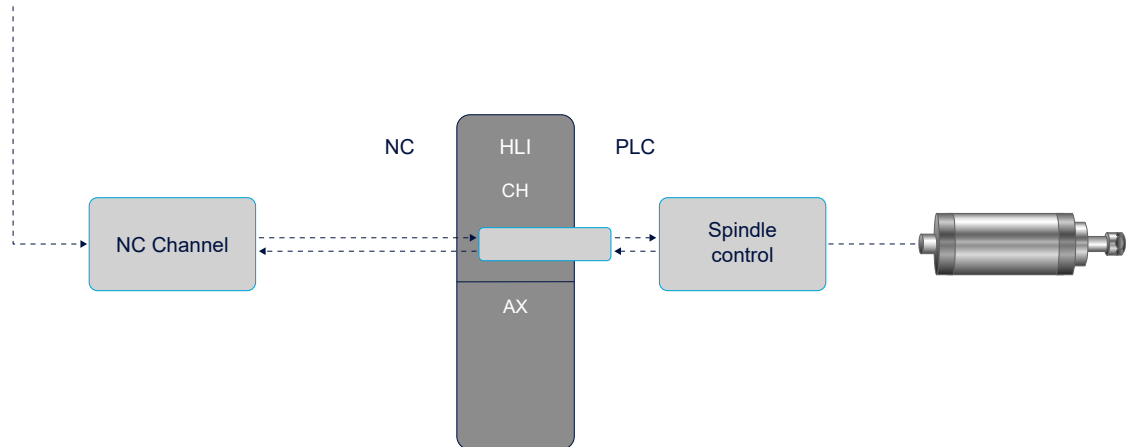

Fig. 6: Channel-specific commanding of a PLC spindle

Parameter

P-CHAN-00069	PLC-controlled spindle
--------------	------------------------



Example

Special application

Spindle S1 is defined as a PLC spindle.

Initialising in the channel parameter list

```

:
spindel[0].plc_control      1
spindel[0].bezeichnung     S1
spindel[0].log_achs_nr     1
:
    
```

Any logical axis number is possible but it must be unequal to 0 and it may not already be assigned to any other axis.

No axis parameter list is required for this kind of PLC spindle.

2.2.3

Main spindle

The main spindle can be programmed together with specific functions (e.g. thread tapping, gear changing, etc.) in conventional DIN syntax.

The main spindle is defined by assigning the parameter P-CHAN-00051. The logical axis number of one of the spindles which is configured in the channel parameters list is entered here. After the controller starts up, this spindle becomes the main spindle.

The NC command #MAIN spindle, see [PROG], can define any other spindle in the system into the main spindle.

The main spindle is assigned an axis name by the parameter P-CHAN-00053 (main_spindle_name) and this is used to address it in the subroutine. The main spindle is always called S. The axis names of the other spindles must also start with S but are otherwise freely selectable.



Notice

Even if there is only one spindle in the system, it must be configured as the main spindle.

Parameter

P-CHAN-00051	Logical axis number of the main spindle
P-CHAN-00053	Designation of the main spindle



Example

Example data record

Example: spindle S1 is defined as the main spindle.

Initialising in the channel parameter list

```
main_spindle_ax_nr      10
main_spindle_name       S

spindel[0].bezeichnung  S1
spindel[0].log_achs_nr  10

spindel[1].bezeichnung  S2
spindel[1].log_achs_nr  11

spindel[2].bezeichnung  S3
spindel[2].log_achs_nr  12
```

2.2.4 Controlled spindle

Functionality

For certain applications it may be sufficient to simply operate a spindle in purely speed-controlled mode by outputting a speed command value instead of operating it in a position-controlled loop.

Drive types

A speed-controlled spindle can be configured for drive types Terminal, Lightbus and EtherCAT/CANopen.

Principle of operation

For a speed-controlled spindle the speed command value of the interpolator is output directly to the axis and not the speed command value of the position controller.

The acknowledgement of speed commands to the spindle is derived from the following actual values depending on the actual value telegram configured:

1. If an actual position value is configured, the actual speed is calculated from the actual position values. However, the encoder resolution must be specified in the axis parameter list.
2. If a speed actual value is configured and not an actual position value, the speed actual value is used to acknowledge the speed.
3. If neither an actual position value nor an actual speed value is configured (sensorless spindle), the speed acknowledgement is calculated from the internal speed command value. The speed is considered as reached when the internal speed command value calculated cycle by cycle is within the speed tolerance specified in the axis parameter list.

A sensorless spindle cannot be positioned. If an attempt to do this is made despite this, error message 70252 is output.

For the actual spindle speed to match the programmed spindle speed, the scaling factor must be correctly adjusted for the speed command value.

A speed-controlled spindle can be configured for drive types Terminal, Lightbus and EtherCAT/CANopen.



Notice

For terminal drives, offset voltages in the analogue input part of the drive controller may lead to a slow rotary spindle movement, even if a spindle speed of 0 is programmed.

This can be prevented by:

- Offset adjustment of the drive amplifier.
- Disabling the drive amplifier by the PLC at speed 0.

2.2.4.1 Example: Configuring a sensorless spindle

If a sensorless spindle is parameterised for a terminal drive: The DA converter terminal supplies an output voltage of 10 V at a digital input value of 32767 digits. The motor turns at a speed of 3000 revolutions/minute at an input voltage of 10 V.

The following steps are required to do this:

1. Configuring a spindle without encoder but with a DA output channel.
2. Setting the operation mode to speed-controlled mode.
3. Parameterising speed scaling.

1. Step

Configuring a spindle without encoder

Normally, configuration is executed with a configuration tool. The basic configuration is executed as for an NC spindle (see section NC spindle [▶ 10]).

2. Step

Configuring speed-controlled mode for the axis

In the axis parameter list, set the parameter P-AXIS-00320 to the value "OPEN_POSITION_LOOP_MODE".

```
antr.operation_mode          OPEN_POSITION_LOOP_MODE
```

3. Step

Parametrising speed scaling

In this case, assign P-AXIS-00207, P-AXIS-00206 and P-AXIS-00205 in the axis parameter list:

The command speed to the drive is specified in revolutions per minute:

```
antr.v_time_base            0
```

An output of 32767 increments turns the motor at 3000 rpm. This corresponds to a speed of $3000 * 360^\circ/\text{min} = 1080000^\circ/\text{min}$.

When converted to the internal format this results in:

$1080000^\circ * 1000 = 1080000000$.

```
antr.v_reso_num             32767
antr.v_reso_denom           1080000000
```

Parameters for sensorless spindle

P-AXIS-00320	Axis operation mode
P-AXIS-00207	Timebase for speed scaling
P-AXIS-00206	Speed scaling nominator
P-AXIS-00205	Speed scaling denominator

2.2.4.2 Example: Configuring a speed-controlled spindle with speed feedback

Configure a speed-controlled spindle whose speed acknowledgement is sent via the speed actual value. The spindle axis turns at the command speed of 1 revolution per minute when the value 1 is output.

The following steps are required to do this:

1. Configuring a spindle with output of a speed command value and feedback of an actual speed value.
2. Setting the operation mode to speed-controlled mode.
3. Parameterising speed scaling.

1. Step

Configuring a spindle

Normally, configuration is executed with a configuration tool. The basic configuration is executed as for an NC spindle (see section NC spindle [▶ 10])

2. Step

Configuring speed-controlled mode for the axis

In the axis parameter list, set the parameter P-AXIS-00320 to the value "OPEN_POSITION_LOOP_MODE".

```
antr.operation_mode          OPEN_POSITION_LOOP_MODE
```

3. Step

Parametrising speed scaling

Set the parameters P-AXIS-00207, P-AXIS-00206 and P-AXIS-00205 in the axis parameter list:

The command speed to the drive is specified in rpm:

```
antr.v_time_base            0
```

At an output of 1 increment, the motor turns at 1 rpm. This corresponds to a speed of $1 \cdot 360^\circ / \text{min} = 360^\circ / \text{min}$.

When converted to the internal format this results in:

$360^\circ \cdot 1000 = 360000$.

```
antr.v_reso_num             1
antr.v_reso_denom          360000
```

Parameters for sensorless spindle

P-AXIS-00320	Axis operation mode
P-AXIS-00207	Timebase for speed scaling
P-AXIS-00206	Speed scaling nominator
P-AXIS-00205	Speed scaling denominator

2.2.5 Other configuration examples

2.2.5.1 Example: Configuring and programming several spindles

3 spindles

Initialisation in the axis parameter list

```
achs_typ      0x00004 Spindel
achs_mode    0x40000 Externally controlled spindles
antr_typ      0x00004 Simulation
```

Initialising in the channel parameter list

```
spdl_anzahl      3
main_spindle_ax_nr  6
main_spindle_name  S

spindel[0].bezeichnung  S1
spindel[0].log_achs_nr  6

spindel[1].bezeichnung  S2
spindel[1].log_achs_nr  11
...

spindel[2].bezeichnung  S3
spindel[2].log_achs_nr  30
...
```

The spindle "S1" with the logical axis number 6 is defined as the main spindle. It is addressed by the spindle name "S". The spindles with logical axis numbers 11 and 30 are programmed by their default names "S2" and "S3".

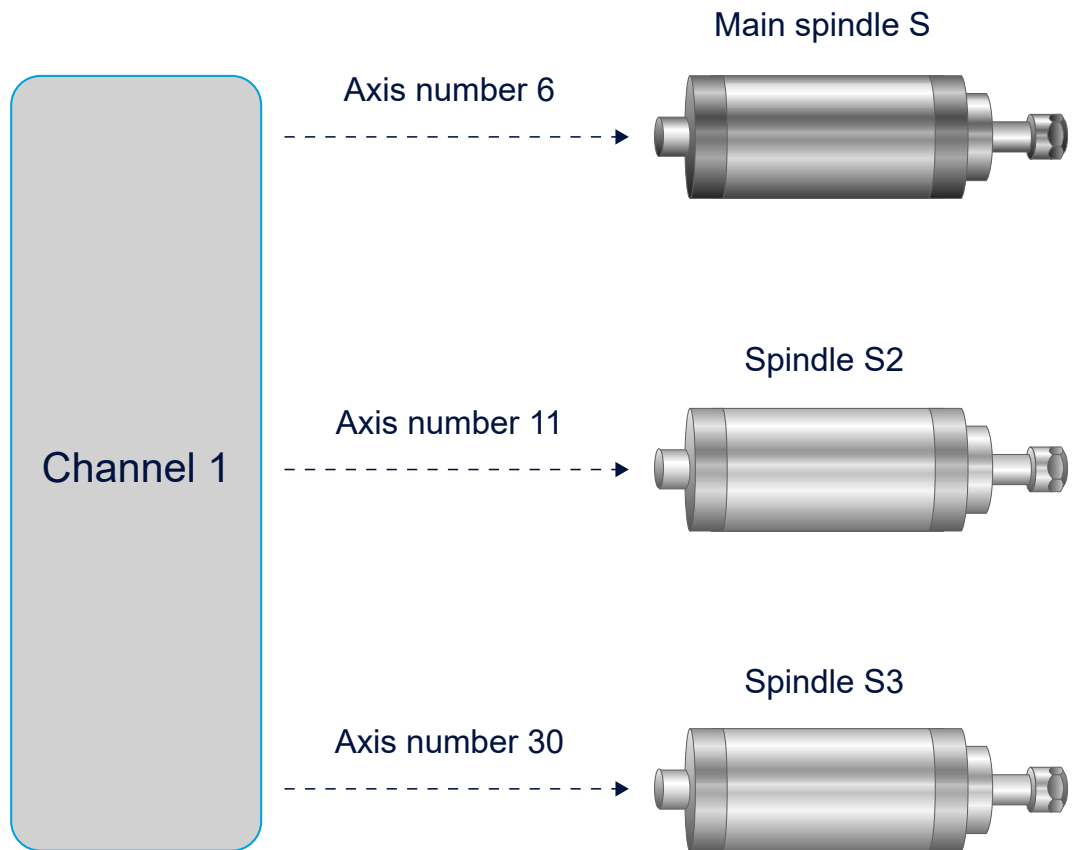

Fig. 7: Interfacing the 3 spindles to channel 1

2.2.5.2 Example: Configuration of a 2-channel system with 3 spindles

Channel 1

Initialisation in the channel parameter list of channel 1:

3 spindles where the spindle with axis number 11 (S2) is to be the main spindle.

```
spdl_anzahl          3

main_spindle_ax_nr   11
main_spindle_name    S
main_spindle_gear_change  0
#
spindel[0].bezeichnung  S1
spindel[0].log_achs_nr  6

spindel[1].bezeichnung  S2
spindel[1].log_achs_nr  11

spindel[2].bezeichnung  S3
spindel[2].log_achs_nr  30
:
```

Channel 2

```
spdl_anzahl          3

main_spindle_ax_nr   11
main_spindle_name    S
main_spindle_gear_change  0
#
spindel[0].bezeichnung  S1
spindel[0].log_achs_nr  6

spindel[1].bezeichnung  S2
spindel[1].log_achs_nr  11

spindel[2].bezeichnung  S3
spindel[2].log_achs_nr  30
```

Initialisation in the channel parameter list of channel 2:

2 spindles where the spindle with axis number 11 (S2) is to be the main spindle.

```
spdl_anzahl          2

main_spindle_ax_nr   11
main_spindle_name    S
main_spindle_gear_change  0
#
spindel[0].bezeichnung  S1
spindel[0].log_achs_nr  6

spindel[1].bezeichnung  S2
spindel[1].log_achs_nr  11
```

Both channels can address the spindle with logical axis number 11 as the main spindle by the spindle name "S". It can be programmed in conventional DIN syntax or in spindle-specific syntax.

Spindle "S1" can also be programmed from both channels in spindle-specific syntax.

Spindle "S3" is only available in channel 1. This spindle is not known in channel 2.

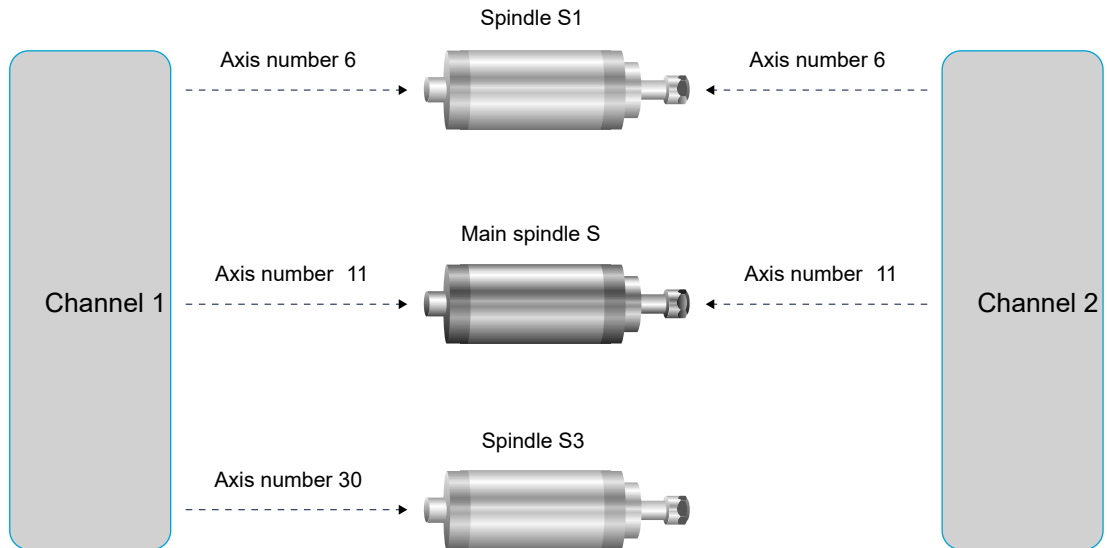

Fig. 8: Interfacing the 3 spindles to channel 1 and channel 2

2.3 Spindle modes

Analogue spindles

In general, the following machine data is assigned when analogue spindles are used:

- In P-AXIS-00015 (achs_mode) the operation mode ACHSMODE_KEINE_AUTO_RPF may **not** be set.
- P-AXIS-00156 (ref_ohne_nocken) == TRUE
- P-AXIS-00157 (ref_ohne_rev) == TRUE

Based on these settings, the following state graph applies:

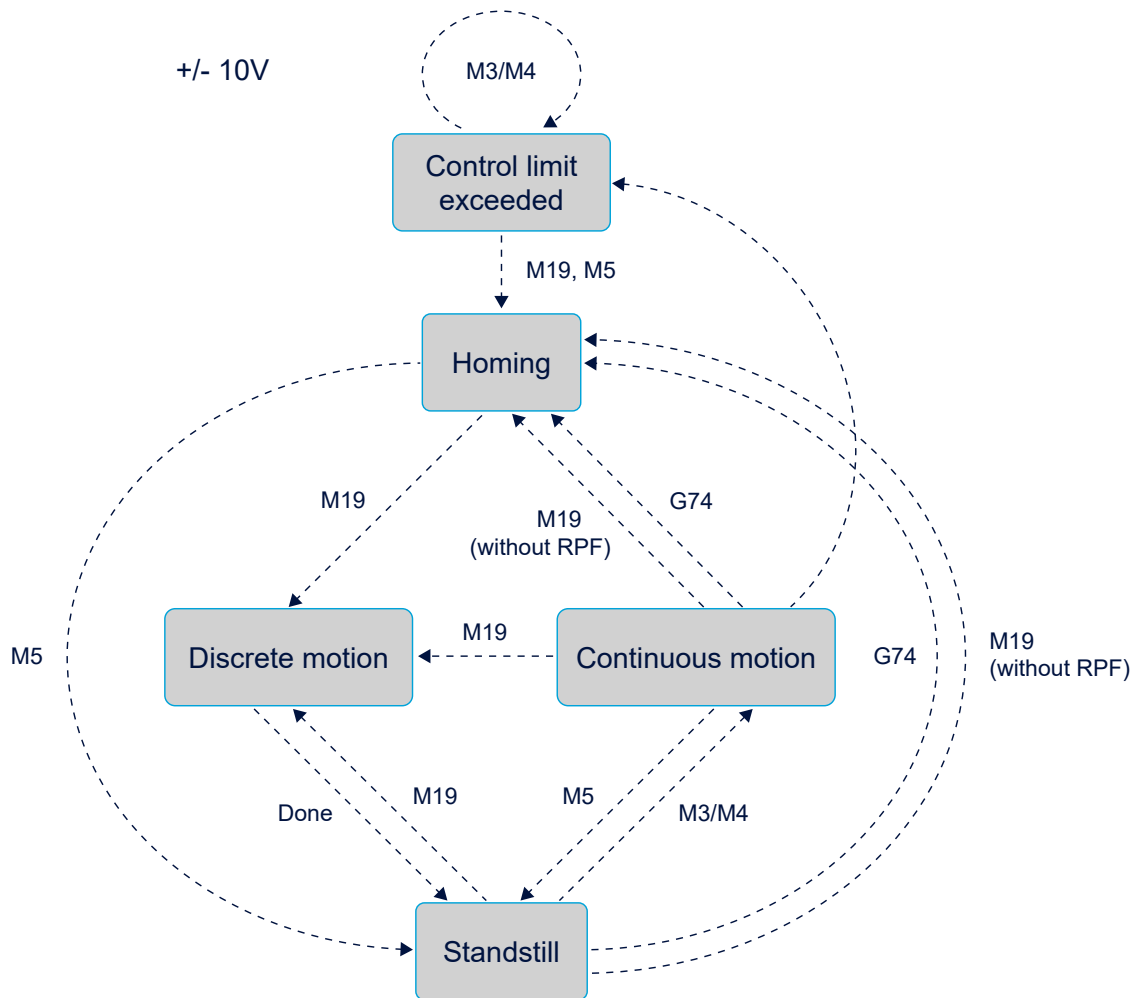

Fig. 9: State graph of spindle modes for analogue drives

Digital spindles

When digital spindles are used (SERCOS), pay attention to the following when setting the machine data [AXIS]:

- In P-AXIS-00015 (achs_mode), the operation mode ACHSMODE_KEINE_AUTO_RPF **must** be set.
- As opposed to analogue spindles the setting of P-AXIS-00156 (ref_ohne_nocken) and P-AXIS-00157 (ref_ohne_rev) has no significance.

Based on these settings, the following state graph applies:

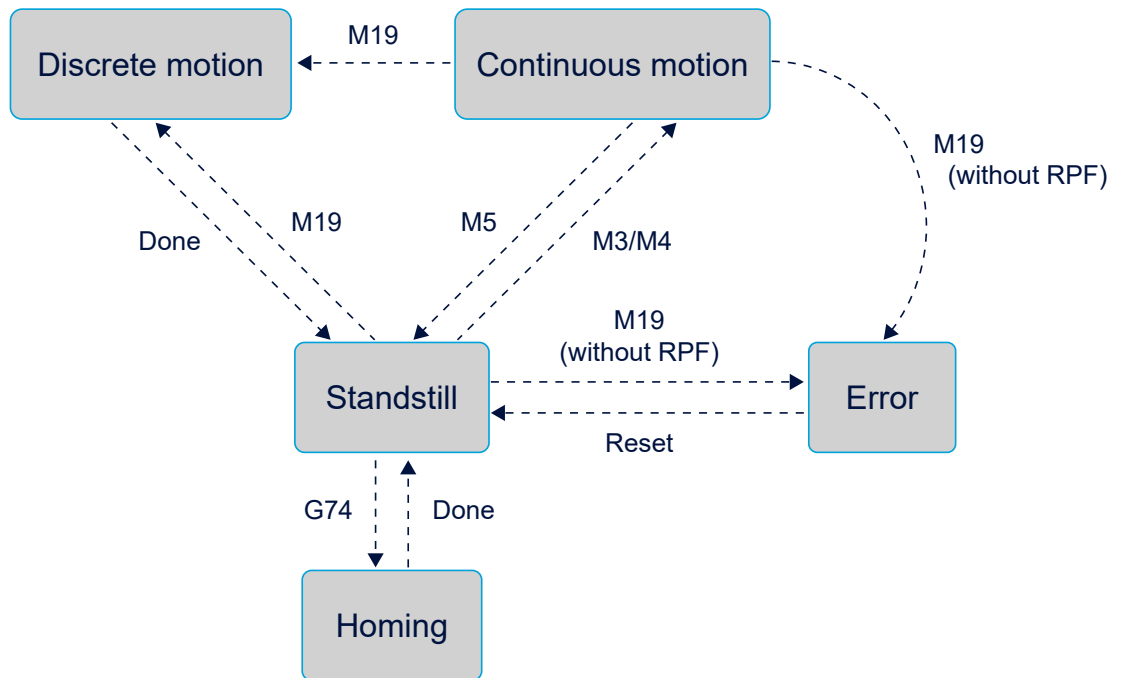

Fig. 10: State graph of spindle modes for digital drives (e.g. SERCOS)

2.3.1 Endless rotation

The endless rotation (M03/M04) functions command speed and direction of rotation. The spindle is accelerated at a constant speed (P-AXIS-00001, or P-AXIS-00002 during the deceleration phase) or an acceleration based on a curve. Endless rotation is terminated by spindle stop (M05), homing (G74) or a set-up block (M19).

DIN66025 programming

M3/M4 S..

Extended syntax

S[M3/M4 REV..]

2.3.2 Positioning

The spindle is positioned at a specified target point at a specified speed.

DIN66025 programming

M19 S.. S.POS.. M3/M4

Extended syntax

S[M19 REV.. POS.. M3/M4]

Observe the following for the direction of rotation:

If a direction of rotation is programmed in connection with M19, set-up takes place in this direction.

If a direction of rotation is not specified for M19,

- distance optimisation takes place from standstill and
- set-up takes place in the current direction of rotation starting from endless rotation.

Preferred direction of rotation

When a preferred direction P-AXIS-00224 (vorz_richtung) and a direction of rotation P-AXIS-00031 (beweg_richt) are specified, all commanded directions of rotation are checked for conformity with the preferred direction. If they do not match, an error message 60254 is issued and the function reverts to error state.

2.3.3 Spindle as channel axis

With machining operations such as tapping without a compensating chuck, face and lateral surface machining etc., the spindle is addressed by the NC channel as a normal axis.

Programming

Transition to this mode is achieved by the programming in the part program [PROG]:

#CAX, G63..

2.4 Spindle behaviour

2.4.1 Spindle override

The rpm or speed of a spindle during endless rotation or positioning can be scaled as a percentage via the override interface on the HLI.

2 control units are used for this axis-specific override.

for CNC Builds > V2.11.2800

1. gpAx[axis_idx]^.ipo_mc_control.override
2. gpAx[axis_idx]^.ipo_mc_control.override_valid

for CNC Builds < V2.11.2800

1. pAC[axis_idx]^.addr^.McControlIpo_Data.MCControlIUNS16Unit_Override/
2. pAC[axis_idx]^.addr^.McControlIpo_Data.MCControlBoolUnit_OverrideValid

The NC command G167 [PROG] can suppress the influence exerted by the override interface.



Programming Example

Spindle override

```
N10 N10 [M3 REV1000      ] (When override is 50%, speed is
                          (500 rpm.)
N20 S2[G167/]           (Override influencing off,)
                          (spindle rotates at 1000 rpm.)
N30 S2[REV3000]         (Override influencing active again,)
                          (speed 1500 rpm.)
N40 M30                 (Program end)
```

2.4.2 Control by CNC

With spindles, the limit at which the measuring system no longer supplies a valid signal may be exceeded at a higher speed. The parameter P-AXIS-00220 (vb_regelgrenze) specifies the speed at which the position control loop is opened and transits to speed-controlled mode. The actual values which are defined by the position lag depending on the specified speed are simulated automatically.

Control is automatically resumed starting from endless rotation when the control limit is under-shot. However, the reference point is then lost. This is why referencing must be repeated before a positioning motion.



Notice

With digital drive systems (e.g. SERCOS), the drive executes the control and monitoring of the control limit.

2.4.3 Behaviour at NC program end or CNC Reset

Program end

The endlessly rotating spindle is only stopped at NC program end if the corresponding flag (spindle stop at program end [HLI]) is set in the HLI interface.

Reset

The spindle is always stopped when the CNC is reset (default). This behaviour can be changed by the parameter P-AXIS-00455.

2.5 Synchronisation

Synchronisation methods

The synchronisation types of spindle M functions M3, M4, M5, M19 and of spindle function S are defined spindle-specifically. The following synchronisation types are permissible:

Constant	Value	Meaning
NO_SYNCH	0x00000000/	No output of S/M function to PLC
MOS	0x00000001/	Output of S/M function to PLC without synchronisation.
MVS_SVS	0x00000002/	Output of the S/M function to the PLC before the motion block, synchronisation before the motion block
MVS_SNS	0x00000004/	Output of the S/M function to the PLC before the motion block, synchronisation after the motion block
MNS_SNS	0x00000008/	Output of the M function to the PLC after the motion block, synchronisation after the motion block
MNE_SNS	0x00000020/	Output of the S/M function to the PLC after a (measurement) event, synchronisation after the motion block (for edge banding option only)
MVS_SLM	0x00004000/	Late synchronisation, output of S/M function to PLC in the block, synchronisation on transition to G01/G02/G03 (implicit synchronisation)
MVS_SLP	0x00008000/	Late synchronisation, output of S/M function to PLC in the block, synchronisation by NC command #EXPL SYN (explicit synchronisation)
PLC_INFO	0x00020000/	Output to PLC, acknowledgement by PLC required, additive bit

PLC_INFO

It only makes sense to use the PLC_INFO bit with NC spindles (position-controlled spindles). In addition to the synchronisation type, the PLC_INFO bit can be set for every spindle M function. This determines whether a spindle M function is output to the PLC or not and whether it must be acknowledged by the PLC.

If the PLC_INFO bit is not set, no output is sent to the PLC and internal synchronisation only takes place based on window monitoring for the position or speed..

With PLC spindles please observe the following:

In general, with every spindle M function, an output of the M function is also sent to the PLC automatically. It is therefore not necessary to additionally set the PLC_INFO bit.



Notice

The synchronisation method of the S function has no effect if a spindle M function is programmed in the NC block. Synchronisation only takes place based on the settings for the spindle M function. The following priorities apply:

M19 > M3/M4/M5 > S

2.5.1 M functions

The M functions M3, M4, M5, M19 and M40 are reserved in DIN66025 for the control of spindles. These M functions can be synchronised with an executing path motion. With M3, M4 and M5, synchronisation always takes place internally (speed reached) and optionally by the PLC additionally.

Moreover, all freely available M functions can be output axis-specifically to a spindle.

For further details of M functions and PLC synchronisation, refer to the documentation [FCT-C1].

M function	Meaning	Channel parameters
M03	Endless clockwise spindle rotation	P-CHAN-00045
M04	Endless counter-clockwise spindle rotation	P-CHAN-00047
M05	Spindle stop	P-CHAN-00049
M19	Spindle positioning	P-CHAN-00043
M40–45	Gear speed selection for the main spindle	See [CHAN // section: Spindle gear change]

2.5.2 Spindle speed - path motion

The spindle must reach the programmed speed before a machining motion begins. The parameter P-CHAN-00081 (s_synch) defines a synchronisation type for speed.



Notice

The synchronisation method of the S function has no effect if a spindle M function is programmed in the same NC block. Synchronisation only takes place based on the settings for the spindle M function. The following priority sequence applies:

M19 > M3/M4/M5 > S



Example

1: Spindle asynchronous to path motion

```

spindel[i].s_synch  0x00000002 Output before, sync. before block
spindel[i].m3_synch 0x00000001 No synchronisation
  
```

```

N10 X0 Y0 G0
N20 X40 Y40 G1 F1500 M3 S500 ;Due to M3 no synchronisation
                               ;Motion starts immediately
N30 M3 S100 X0 Y0           ;Path executes motion without waiting
                               ;until spindle speed is reached
  
```

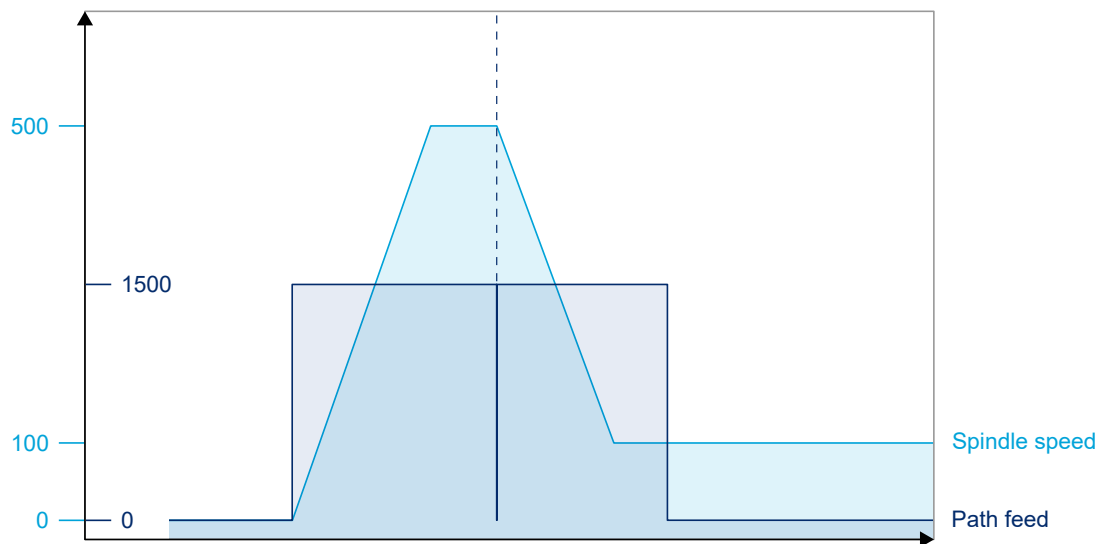

Fig. 11: Spindle not synchronised with path motion



Example

2: Spindle synchronous with path motion

```

spindel[i].s_sync  0x00000002 Output before, sync. before block
spindel[i].m3_sync 0x00000001 No sync.

```

```

N10 M3 X0 Y0 G0
N20 X40 Y40 G1 F1500 S500 ;Path motion only starts when
                           ;spindle speed is reached
N30 S100 X0 Y0           ;Path waits before executing motion
                           ;until spindle speed is reached

```

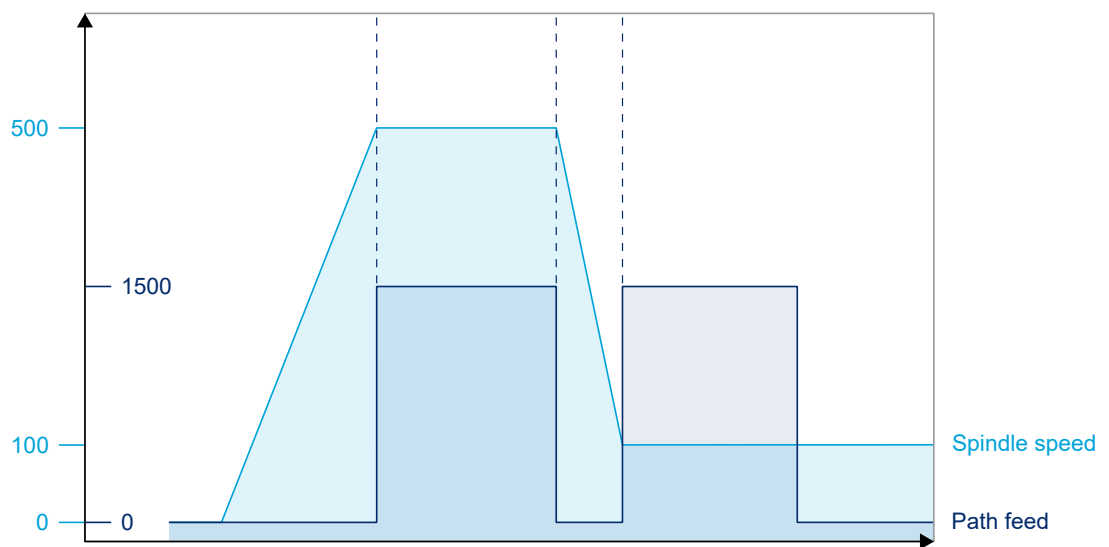

Fig. 12: Spindle synchronised with path motion

2.6 Spindle monitoring

Overview of monitoring mechanisms for an NC spindle

- Dynamic monitoring (speed, acceleration) [FCT-D1]
- Revolution monitoring
- Position monitoring [FCT-A3]
- Position lag monitoring [FCT-A1]
- Time monitoring [FCT-A3]
- Monitoring the direction of rotation

Speed

The parameter P-AXIS-00217 defines the actual speed at which nominal speed is regarded as reached.

The parameter P-AXIS-00216 defines the speed limit under which the zero speed is assumed.

Direction of rotation

If a preferred direction P-AXIS-00224 and a direction of rotation P-AXIS-00031 are specified, all commanded directions of rotation are checked for matching with the preferred direction.

If they do not match, the error message P-ERR-60254 is issued and the function reverts to error state.

2.7 Homing for NC spindles

To execute spindle positioning, the coordinate zero point must be synchronised with the signals of the actual value measuring system by a reference marker. With spindles, this can take place during endless rotation without standstill. For example, the zero point passage of the actual value encoder is used.

Automatic homing

If no homing took place for the spindle, it is executed automatically before positioning with M19 takes place or if positioning or stopping the spindle with M05 takes place after the control limit speed is exceeded (see the figure in section Spindle operation modes [▶ 23]).



Notice

With digital drive systems (e.g. SERCOS), drive-controlled homing is executed using the command (G74). Automatic homing is not possible. This must be deactivated by axis parameter P-AXIS-00015.

Programming



Example

Homing for NC spindles

G74 S1 or S[G74]

Homing spindles and other axes can be started simultaneously but is otherwise not synchronised.

1. Homing the spindle starts simultaneously with Y axis homing:

```
N10 G74 X2 Y1 S1
```

2nd Same as 1. The system continues to the next NC block without waiting until the spindle is referenced so that the X axis is referenced quasi simultaneously:

```
N10 G74 S1  
N15 G74 X1 Y2
```

3rd Axes X and Y are first referenced. Spindle referencing then starts:

```
N10 G74 X1 Y2  
N15 G74 S1
```

A detailed description of homing for axes and spindles is contained in the documentation [FCT-M1].

2.8 Spindle functions

2.8.1 Feed forward

Spindle position lag can be minimised by using speed and acceleration feedforward control.

Spindle feedforward control is required especially to tap threads with an endlessly rotating spindle since both the path axes and the spindle must keep to the specified setpoints as far as possible without position lag if a good machining result is to be achieved.

Conventional feedforward control

This type of feedforward control is only possible for conventional drives and for drive simulation.

The theoretical position lag is then calculated based on the current speed and acceleration and is added to the setpoint specified by the interpolator. The expected position lags can be calculated by the relation

$$\delta_{s,v} = \frac{v}{k_v}$$

for constant speed and

$$\delta_{s,a} = \frac{a * T_a}{k_v}$$

for constant acceleration. T_a is the drive time constant which can be set in the axis parameter list P-AXIS-00225/ P-AXIS-00226.

Maintaining the permissible axis acceleration values is taken into account when the feedforward control variable is added to the specified setpoint.

The condition for the described equations is use of a P position controller whose velocity gain for linear axes

$$k_v = \frac{v}{\delta_s}$$

or speed gain for rotation axes

$$k_v = \frac{v}{\delta_\Phi}$$

are essentially defined by the drive dynamics.

Path fidelity

If all axes of a system have the same k_v factor, there are no deviations from the specified path, neither with straight ahead nor circular motion after stabilisation. A position lag is only executed according to the equations described above.

Sampling time and prefiltering

When velocity v and acceleration a are derived from differentiation of the distance, make sure that sampling times are sufficiently long to minimise undesirable quantisation noise. Improved response is also achieved by prefiltering v and a . For this reason, several values of v and a are averaged linearly.

Settings

Feedforward control leads to an increase in dynamic acceleration stress and an increase in control ranges. An improvement in path fidelity by feedforward control is only possible with position controller settings whose velocity or speed gain is less than the optimum values required for response to setpoint changes since otherwise there is an extreme inclination to overshoot.

Coupling in feedforward control

Activating or deactivating feedforward control during the motion may lead to oscillations. This is why it is necessary to use 'soft' coupling for feedforward control. This includes the maximum permitted axis acceleration values or maximum jerk (e.g. for the non-linear 'slope' function). This permits activation or deactivation of feedforward control as required at block boundaries without interrupting the motion. Wear and tear on the drive and also on the mechanics of the machine tool can be reduced by activating feedforward control for paths which require precise machining.



Notice

Further information on the subject of feedforward control and parameterisation is contained in the description of functions [FCT-D2].

Programming

S[G135]	Spindle feedforward control on
S[G136]	Specify weighting
S[G137]	Spindle feedforward control off



Notice

With digital drive systems (e.g. SERCOS), feedforward control can be activated and parameterised in the drive.

After homing and positioning with M19, the spindle is always stopped with exact stop.

2.8.2 Gear change

activation

The channel parameter P-CHAN-00052 (main_spindle_gear_change) enables gear changes and the related reserved use of the M functions M40-45.



Notice

Gear changes can only be programmed for the main spindle in DIN syntax [PROG//Gear change].

6 gear speeds or data records are available for programming in combination with the S word and M40 - M45 functions. After start-up of the NC controller, the default gear speed specified in the axis machine data record P-AXIS-00079 (getriebe_stufe) is activated.

Approach the change position

The rapid traverse velocity specified in the axis machine data record P-AXIS-00209 (vb_eilgang) moves the axis to the change position of the current gear P-AXIS-00078 (getr_schalt_pos). If the gear has no preferred direction, the direction of rotation is selected to optimise the motion path.

The change operation is normally undertaken by the PLC. Adjustments must be made in the NC controller to adopt the parameters of the new gear. A distinction must be made between two cases here:

1. The measuring system is coupled to the motor shaft. Depending on the gear speed, the measuring system resolution must be adapted (factors in the axis machine records: P-AXIS-00233 (wegaufz), P-AXIS-00234 (wegaufn).
2. The measuring system is coupled to the gear shaft. The measuring system resolution must be retained and the control dynamics of the gear speed must be adapted. Factors in the axis machine data record: P-AXIS-00128 (multi_gain_n), P-AXIS-00129 (multi_gain_z), P-AXIS-00099 (kv).

Parameterise the speed ranges

Each of the 6 gear speeds covers a specific speed range which is defined by a minimum P-CHAN-00058 (min_speed) and a maximum P-CHAN-00055 (max_speed) speed (unit: rpm). Speed range overlaps are permitted. The minimum and maximum speeds of the unused speed ranges must be assigned the value 0.

Automatic gear speed selection

When automatic gear speed selection P-CHAN-00004 (autom_range=1) is used, the gear speed from the programmed speed S is defined using the speed table. The M functions M45 are not programmed.

The parameter P-CHAN-00074 (range_way) specifies the direction in which the automatic gear speed selection searches for the suitable speed range in the table during gear speed selection (from speed 1 to 6 ("bottom up") or from speed 6 to 1 ("top down")).

Manual gear speed selection

Manual gear speed selection P-CHAN-00004 (autom_range= 0) requires programming of the M functions M40 - M45 together with the speed S. A message is output if the speed S is not within the programmed speed range.

Minimise change operations

Generally, the control system attempts to minimise change operations. A gear speed selection is not executed if a new speed is run at the current gear speed.

Configuration example

Definition of M40 - 45 and synchronisation methods.

```
m_synch[1]          0x00000001      MOS
m_synch[2]          0x00000002      MVS_SVS
:
m_synch[40]        0x00000002      MVS_SVS
m_synch[41]        0x00000002      MVS_SVS
m_synch[42]        0x00000002      MVS_SVS
m_synch[43]        0x00000002      MVS_SVS
m_synch[44]        0x00000002      MVS_SVS
m_synch[45]        0x00000002      MVS_SVS
m_synch[48]          0x00000008      MNS_SNS
m_synch[49]        0x00000002      MVS_SVS
```

Enabling the M functions M40-45 and gear changing:

```
:
main_spindle_gear_change      1      0: OFF 1: ON
:
```

Parameterise the spindle gear (search direction, speed ranges):

```
spindel[0].range_way          0      0:bottom up 1:top down
#
spindel[0].range_table[0].min_speed  50      (M40)
spindel[0].range_table[0].max_speed  560     (M40)
spindel[0].range_table[1].min_speed  400     (M41)
spindel[0].range_table[1].max_speed  800     (M41)
spindel[0].range_table[2].min_speed  700     (M42)
spindel[0].range_table[2].max_speed  3500    (M42)
spindel[0].range_table[3].min_speed  3501    (M43)
spindel[0].range_table[3].max_speed  4000    (M43)
spindel[0].range_table[4].min_speed  3800    (M44)
spindel[0].range_table[4].max_speed  5500    (M44)
spindel[0].range_table[5].min_speed  5400    (M45)
spindel[0].range_table[5].max_speed  7000    (M45)
#
```

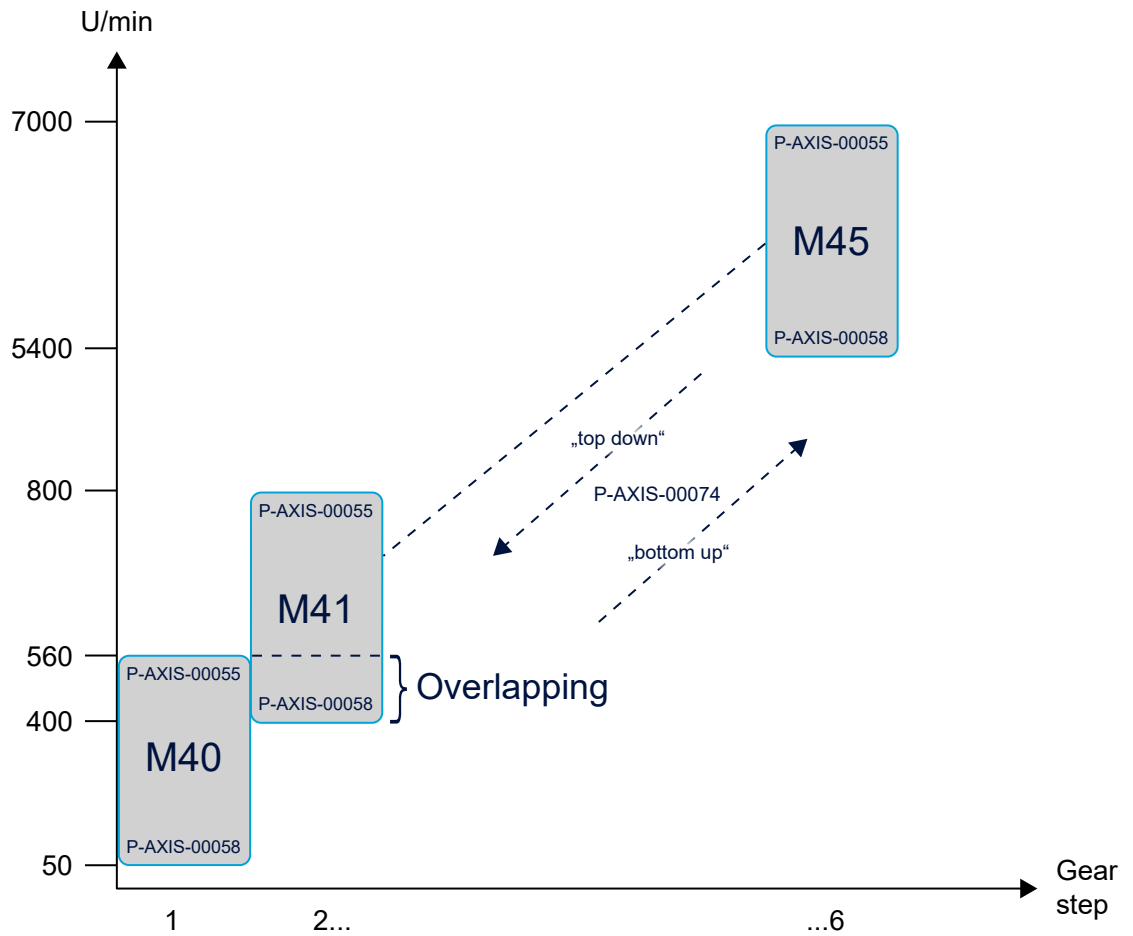

Fig. 13: Define the speed ranges according to the example



Programing Example

Automatic gear stage determination: ON

```

:
spindel[0].autom_range      1
:

NC program:
S650 M03      OK, M41→ PLC
S750          OK, no change, M41 already selected
S950          OK, automatic change, M42 → PLC
S1050         OK, no change, M42 already selected
S750          OK, automatic change, M41 → PLC
S500          OK, no change, M41 already selected
S350          OK, no change, M41 already selected
S8000         Error, speed too high
A programmed gear stage is always checked:
M41 S750      OK, "automatic" change, M41 → PLC

..but
M40 S750      Error, wrong gear stage
    
```



Programing Example

Determine the automatic gear stage: OFF

```
:
spindel[0].autom_range      0
:
NC program:
M41 S650 M03  OK, M41 → PLC
M41 S750      OK, no change, M41 already selected
M42 S950      OK, change, M42 → PLC
M42 S1050     OK, no change, M41 already selected
M41 S750      OK, change, M41 → PLC
M41 S500      OK, no change, M41 already selected
M41 S350      OK, no change, M41 already selected

M41 S200 Error, program different gear stage (M40)
S950          Error, no gear stage (M42) programmed
```

2.8.3 Synchronous operation

When synchronous operation is active, spindle commanding for coupled spindle axes is mapped by the master spindle onto the slave spindles, i.e. implicit parallel command of slave axes takes place.

Coupling specifications for spindle axes are defined analogously to those of path axes [PROG//Synchronous operation].

Coupled spindles are commanded in parallel. Setpoints are not coupled synchronously with cycles.

There is no need for the separate commands for slave spindles for speed or positioning commands otherwise required in the NC program or for the technology functions and their acknowledgements.

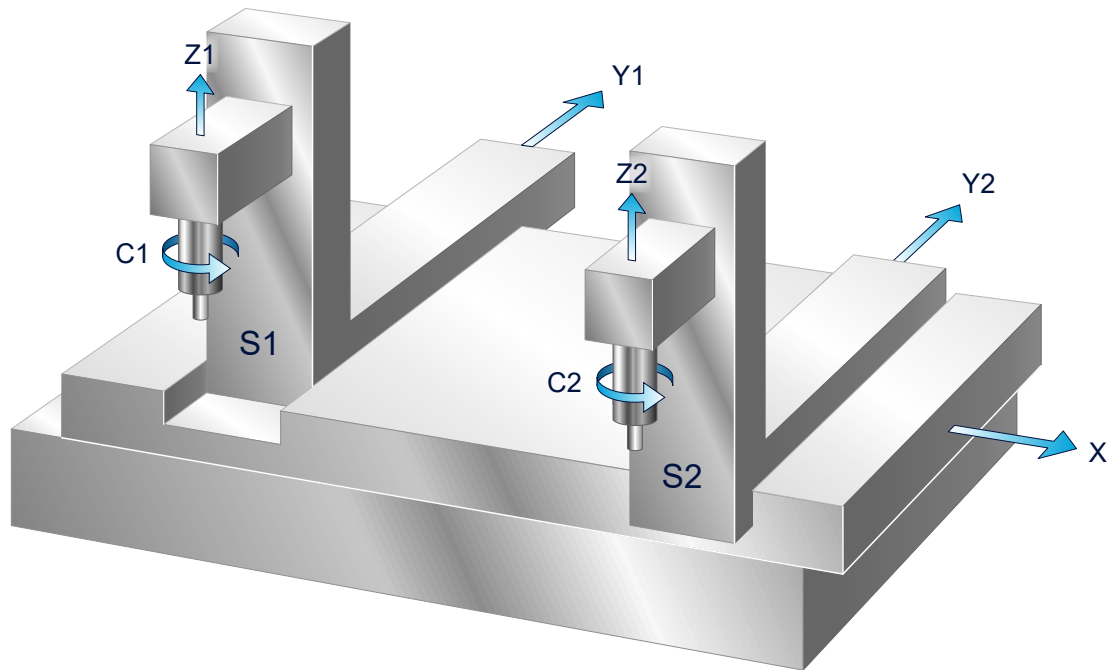

Fig. 14: Example of a machine structure for synchronous operation with spindles

Characteristics:

2-axis systems with one common X axis

Master system: X, Y1, Z1, C1, S1

Slave system: Y2, Z2, C2, S2

Default assignment in channel parameters

In the channel parameters [CHAN//Synchronous mode settings] spindles can be assigned defaults for synchronous mode as coupling pairs in coupling group 0:

Parameter

P-CHAN-00037	Logical no. of master axis
P-CHAN-00038	Logical no. of slave axis
P-CHAN-00061	Mode (for spindle axis: 1)



Programming Example

Axis coupling defaults:

```
koppelgruppe[0].paar[i].log_achs_nr_slave  log. no. slave axis
koppelgruppe[0].paar[i].log_achs_nr_master log. no. master axis
koppelgruppe[0].paar[i].mode              Spindle axis (1)
i: coupling pair
```

```
koppelgruppe[0].paar[0].log_achs_nr_slave  6
koppelgruppe[0].paar[0].log_achs_nr_master  1
koppelgruppe[0].paar[0].mode
```

Programming

Synchronous mode of spindles is programmed in the NC program by means of the following NC commands [PROG//Selecting and deselecting axis couplings]:

Definition of a coupling specification:

```
#SET AX LINK[...]
```

Select synchronous mode:

```
#ENABLE AX LINK[...]
```

Deselect synchronous mode:

```
#DISABLE AX LINK
```

The default assignments in the channel parameters can be selected in the NC program

```
#ENABLE AX LINK[0]
```

with



Notice

Synchronous mode for spindles cannot be used in combination with rotary functions.

2.8.4 Curve-controlled acceleration

Servo and main spindle motors can perform better with digital drive technology than with analogue technology, i.e. the motors can be operated closer to their performance limits.

To fully exploit a motor during acceleration, it can be operated at its commutation limit curve. This curve defines the maximum available torque as a function of speed. It has been observed that motors can sometimes output 1.5 to 2 times the torque at up to half the nominal speed compared to the nominal speed.

For an endlessly rotating spindle, setpoint generation can be set to such a speed-dependent acceleration curve.

Typically the acceleration curve is constant in the lower speed range and then drops after a speed limit n_{limit} according to a specified curve:

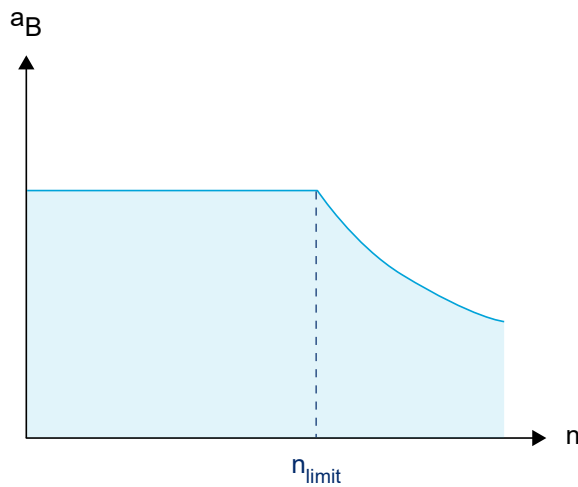

Fig. 15: Acceleration curve as a function of speed

As this acceleration curve varies for individual spindle gears, a corresponding data record must be provided for each gear.

Two methods are provided to define the acceleration curve and they can be selected by the machine parameter P-AXIS-00202.

2.8.4.1 Method 1: Characteristic curve $a(n)$ in polynomial- or hyperbola form

In the range above the limit speed, the current acceleration is optionally specified by a third-order polynomial or by a hyperbola function. In the case of both characteristics, a constant acceleration a_{konst} is used in the range below n_{grenz} . This corresponds to acceleration at nominal speed. The curves apply to both the speed build-up and slow-down phases.

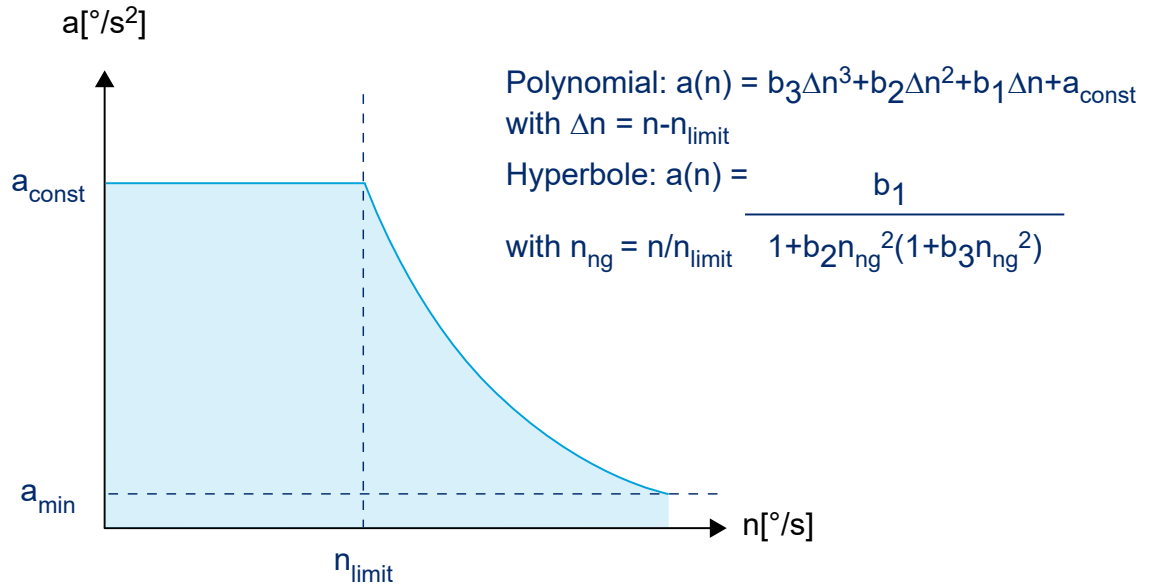

Fig. 16: Profile of acceleration based on a polynomial or hyperbole

Interpolation points on the drive curve $a(n)$ are used to determine the coefficients of the curves. 4 or 3 interpolation points are required to determine them.

One interpolation point $P1=(n_1, (a(n_1)))$ is already defined by the parameter for constant acceleration a_{konst} and the limit speed n_{grenz} and the user can define the remaining 3 or 2 on the drive characteristic $a(n)$. It is best for the abscissa values to be at a constant distance. The equations to determine the coefficients are listed below.

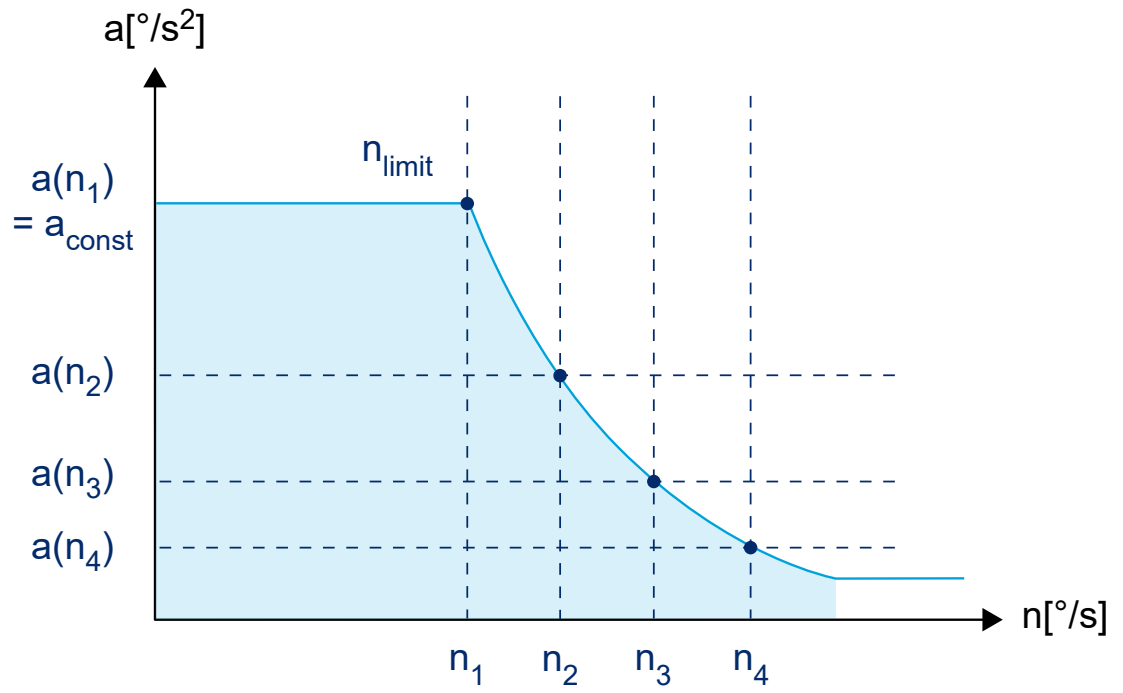

Fig. 17: Acceleration profile based on polynomial or hyperbole with interpolation points

Polynomial

$$a(n) = b_3 \Delta n^3 + b_2 \Delta n^2 + b_1 \Delta n + b_0$$

$$\Delta n = n_{limit} - n$$

, relative speed

$$n = n_{limit} \Rightarrow b_0 = a_{const}$$

$$b_3 = \frac{\Delta n_4 (a_{const} - a(\Delta n_2)) - \Delta n_2 (a_{const} - a(\Delta n_4))}{\Delta n_4 \Delta n_2 (\Delta n_4 - \Delta n_2) (\Delta n_4 - \Delta n_2)} - \frac{\Delta n_3 (a_{const} - a(\Delta n_2)) - \Delta n_2 (a_{const} - a(\Delta n_3))}{\Delta n_3 \Delta n_2 (\Delta n_3 - \Delta n_2) (\Delta n_4 - \Delta n_3)}$$

$$b_2 = \frac{\frac{\Delta n_3}{\Delta n_2} (a_{const} - a(\Delta n_2)) - b_3 \Delta n_3 (\Delta n_3^2 - \Delta n_2^2) - (a_{const} - a(\Delta n_3))}{\Delta n_3 (\Delta n_3 - \Delta n_2)}$$

$$b_1 = - \frac{(a_{const} - a(\Delta n_2))}{\Delta n_2} - b_3 \Delta n_2^2 - b_2 \Delta n_2$$

Example of curve determination

Interpolation point	Acceleration a [°/s ²]	Speed n [°/s]
1	16000	12000
2	8000	24000
3	4000	36000
4	2000	48000

$$a_{const} = 16000 \text{ [°/s}^2\text{]} \text{ to } n_{limit} = 12000 \text{ [°/s]}$$

The following is obtained for the coefficients:

$$b_3 = -1.92901234E-10 \text{ [s/}^{\circ}\text{]}^2$$

$$b_2 = 2.08333333E-5 \text{ [1/}^{\circ}\text{]}$$

$$b_1 = -0.88888888 \text{ [1/s]}$$

$$b_0 = a_{konst} = 16000 \text{ [°/s}^2\text{]}$$

As from nominal speed (n_{limit}) the characteristic profile is as follows::

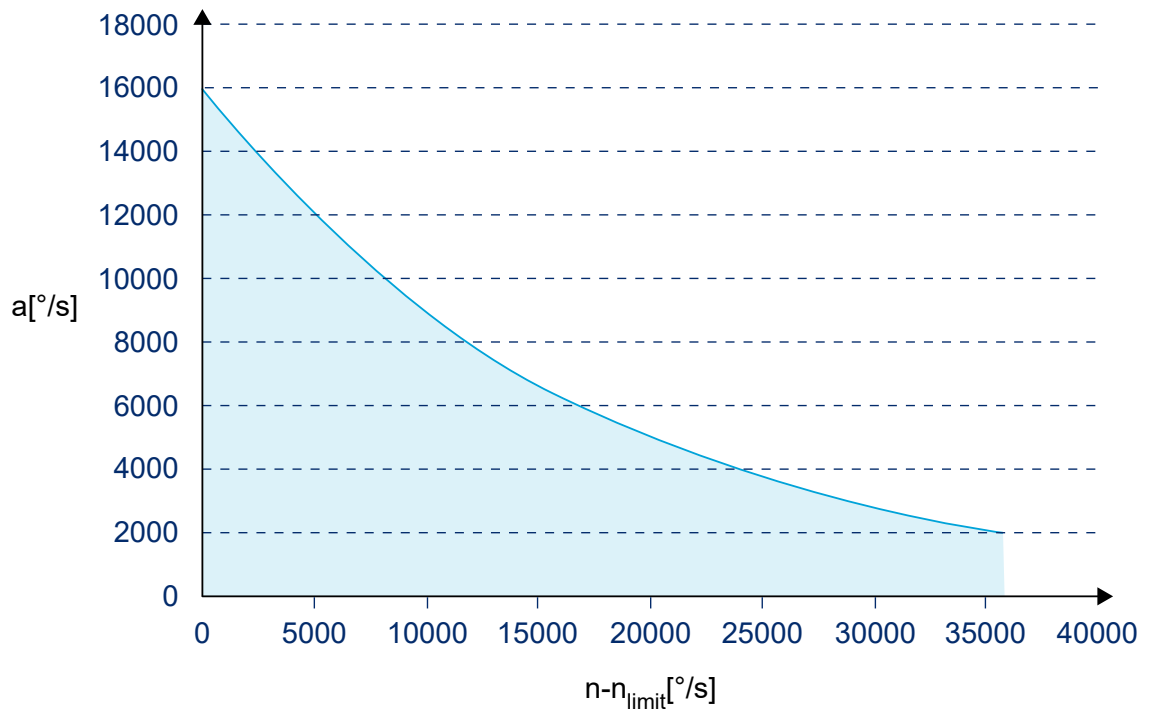

Fig. 18: Curve profile for nominal speed n_{limit} with polynomials

Hyperbola

$$a(n) = \frac{b_1}{1 + b_2 n_{norm}^2 * (1 + b_3 n_{norm}^2)}$$

$$n_n = \frac{n}{n_{limit}}, \text{ normalised speed, } a(n = n_{limit}) = a_{const}$$

$$b_{2N} = \frac{(a_{const} - a(n_{n3}) * n_{n3}^2) * (a_{const} - a(n_2) * n_{n2}^4)}{-(a_{const} - a(n_{n2}) * n_{n2}^4) * (a_{const} - a(n_{n3}) * n_{n3}^4)}$$

$$b_{2N} = \frac{(a_{const} - a(n_{n3}) * n_{n3}^2) * (a_{const} - a(n_2) * n_{n2}^4)}{-(a_{konst} - a(n_{n2}) * n_{n2}^4) * (a_{konst} - a(n_{n3}) * n_{n3}^4)}$$

$$b_2 = \frac{b_{2Z}}{b_{2N}}$$

$$b_3 = \frac{\frac{a(n_{n2}) - a_{const}}{b_2} - (a_{const} - a(n_{n2}) * n_{n2}^2)}{a_{const} - a(n_{n2}) * n_{n2}^4}$$

$$b_1 = a_{const} * (1 + b_2 * (1 + b_3))$$

Example of curve determination

Interpolation point	Acceleration a [$^{\circ}/s^2$]	Speed n [$^{\circ}/s$]
1	16000	12000
2	8000	24000
3	4000	36000
4	2000	48000

$A_{\text{konst}_{\text{konst}}} = 16000[\text{degrees}/s^2]$ to $n_{\text{limit}} = 12000$ [degrees/s]

The following is obtained for the coefficients:

$$b_2 = 4.166666E-1 []$$

$$b_3 = 2.857142E-2 []$$

$$b_1 = 2.285714E4 [^{\circ}/s^2]$$

As from nominal speed (n_{limit}) the characteristic profile is as follows::

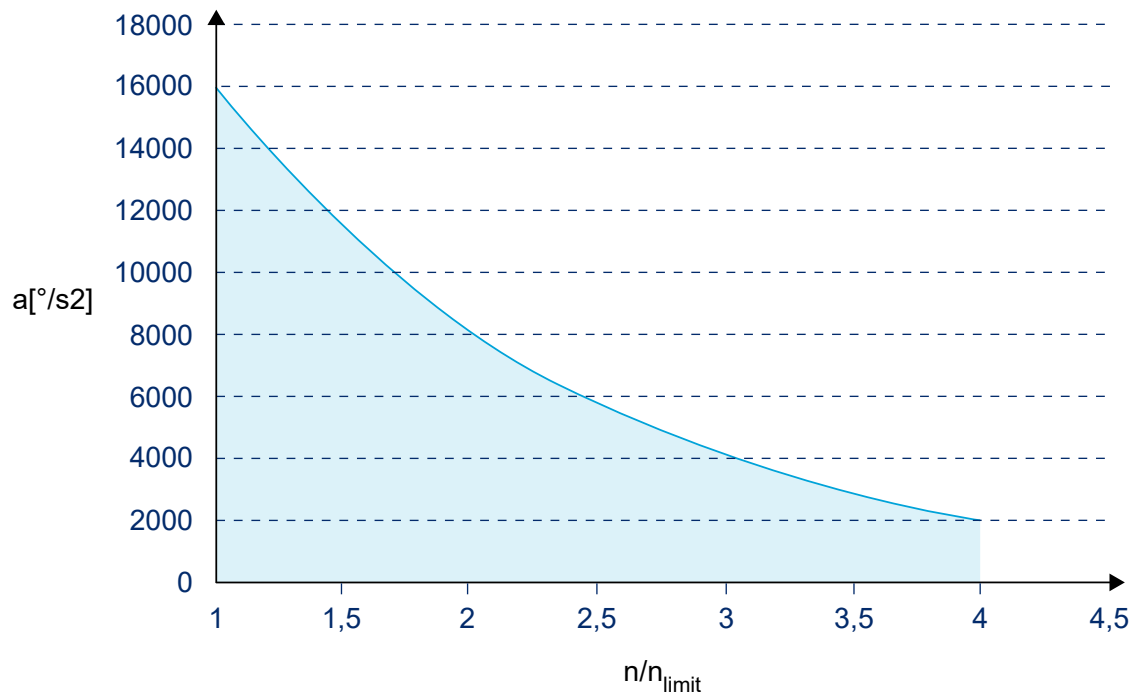

Fig. 19: Curve profile for nominal speed n_{limit} with hyperbola

Parameter

P-AXIS-00202	Type: 1 (hyperbola) or 2 (polynomial)
P-AXIS-00130	Limit speed n_{limit}
P-AXIS-00007	Constant acceleration a_{const} for $n < n_{\text{limit}}$
P-AXIS-00010	Minimum acceleration a_{min}
P-AXIS-00026	Coefficient b1
P-AXIS-00027 [► 87]	Coefficient b2
P-AXIS-00028 [► 87]	Coefficient b3

Parameterisation examples

```

#
beschl_kennlinie.typ          1          Hyperbola shape
beschl_kennlinie.a_min       1400       [°/s*s]
beschl_kennlinie.n_grenz     12000000  [10-3 °/s]
beschl_kennlinie.a_konst     16000   [°/s*s]
beschl_kennlinie.b1          2.285714E4 [°/s*s]
beschl_kennlinie.b2          4.166666E-1 []
beschl_kennlinie.b3          -2.857142E-2 []
#
#
beschl_kennlinie.typ          2          Polynomial shape
beschl_kennlinie.a_min       2000       [°/s*s]
beschl_kennlinie.n_grenz     12000000  [10-3 °/s]
beschl_kennlinie.a_konst     16000   [°/s*s]
beschl_kennlinie.b1          -0.88888888 [1/s]
beschl_kennlinie.b2          2.08333333E-5 [1/°]
beschl_kennlinie.b3          -1.92901234E-10 [s/°2]
#

```

2.8.4.2 Method 2: Characteristic curve for asynchronous drives

Asynchronous motors are often used for spindle drives. You can achieve optimised adaptation to typical characteristic of such spindle drives using the speed-dependent spindle acceleration curve $a=f(n)$ shown in the figure below.

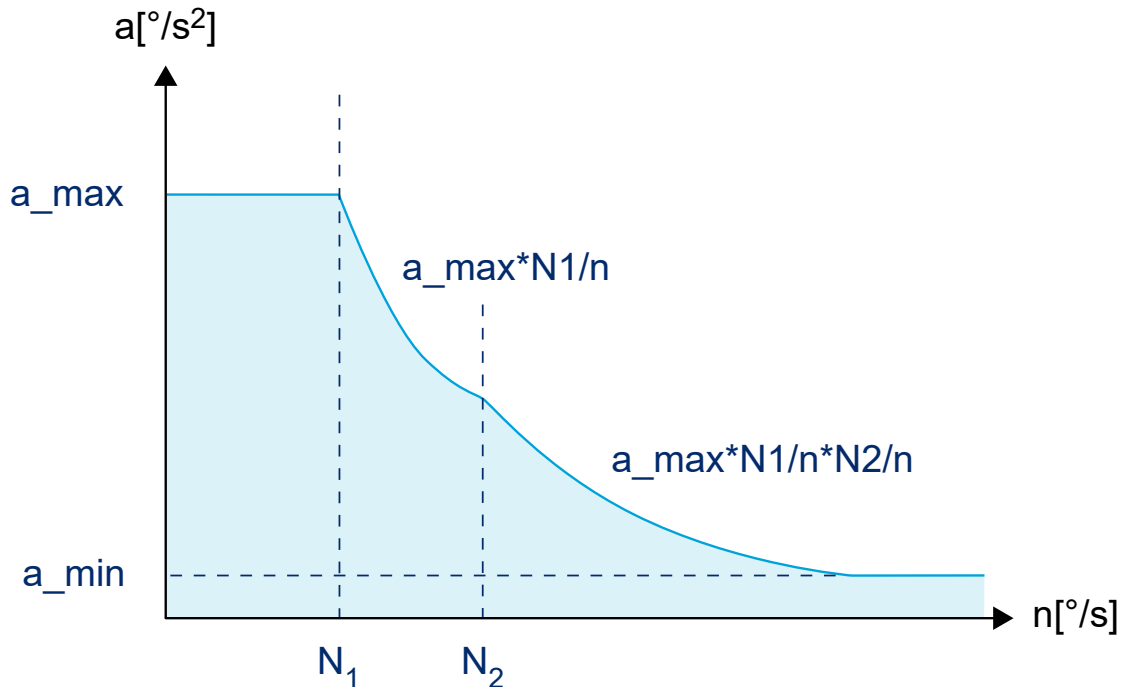

Fig. 20: Acceleration profile with asynchronous drive curve

Besides the maximum permitted acceleration a_{max} , speed N_1 for the constant acceleration range, you need only parameterise an additional speed N_2 and the upper minimum acceleration a_{min} . Acceleration is constant up to the speed N_1 . Above N_1 , acceleration is proportional to $1/n$, and above N_2 it is proportional to $1/n^2$.

$N_1=10000 \text{ }^{\circ}/s$	$N_2=20000 \text{ }^{\circ}/s,$	$a_{max}=16000 \text{ }^{\circ}/s^2$
--------------------------------	---------------------------------	--------------------------------------

Above the nominal speed (n_{limit}) the characteristic profile is as follows:

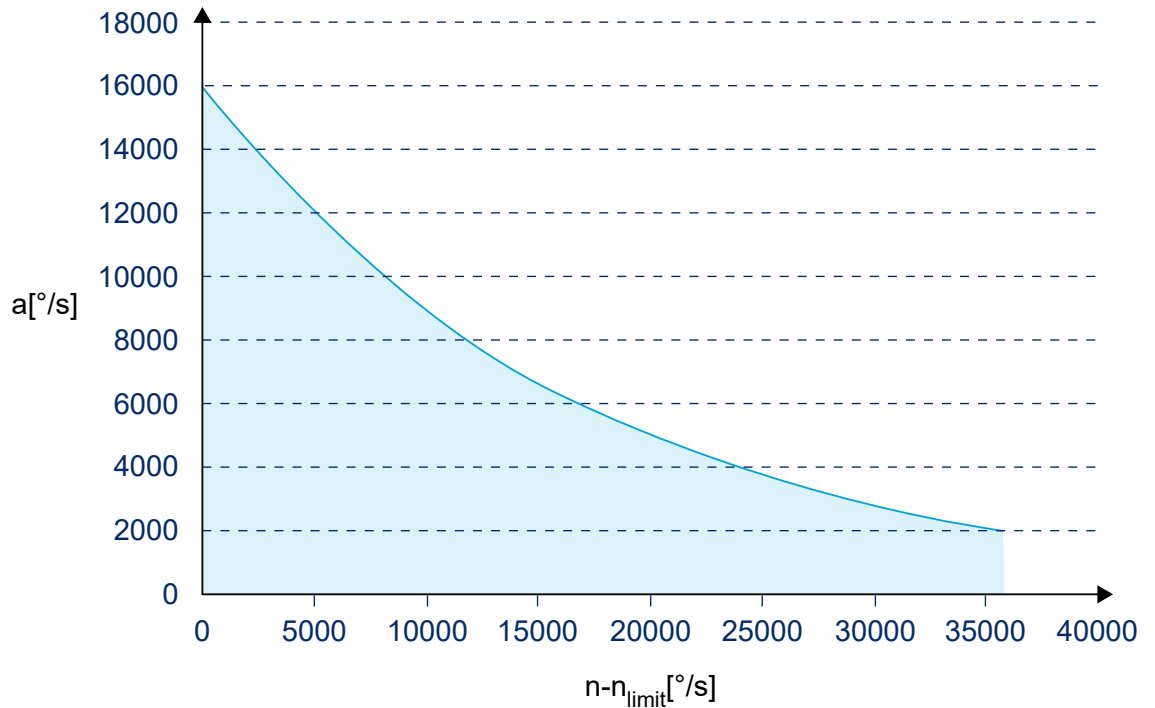

Fig. 21: Curve profile above nominal speed

Parameter

P-AXIS-00202	Curve type 3: Asynchronous drive
P-AXIS-00010	Minimum acceleration a_{min}
P-AXIS-00240	Maximum acceleration a_{max} for $n < N_1$
P-AXIS-00241	Speed limit N_1 for maximum torque
P-AXIS-00242	Speed limit N_2 for maximum output

Programming Example
Parameterisation example

```

getriebe[0].beschl_kennlinie.typ      3 Asynchronous drive
getriebe[0].beschl_kennlinie.a_max   16000    [°/s2]
getriebe[0].beschl_kennlinie.a_min   4000     [°/s*s]
getriebe[0].beschl_kennlinie.n1      10000000 [10-3 °/s]
getriebe[0].beschl_kennlinie.n2      20000000 [10-3 °/s]
    
```

2.8.5 Tool-related dynamic limiting for spindles

The dynamic behaviour of spindles can be modified by a tool change depending on the entry in the tool data. Spindle behaviour can then be adapted to the permissible dynamic loads of the tool.

The tool is assigned in the tool data [TOOL] to a spindle via the logical axis number.

The tool dynamic data takes effect automatically on transition of the spindle from standstill to interpolation after programming a new tool (D word, #TOOL DATA).

After deselecting the tool, the dynamic curves of the tool last selected remain valid.

Parameter

P-TOOL-00012	Logical axis number of the spindle axis
P-TOOL-00013	Minimum speed
P-TOOL-00014	Maximum speed
P-TOOL-00015	Maximum acceleration



Programming Example

Tool-related dynamics limiting

```
wz[i].log_ax_nr_spdl      6
wz[i].vb_min             60000    [10-3 °/s]
wz[i].vb_max             3000000  [10-3 °/s]
wz[i].a_max               3000    [°/s2]
```

Programming

D word or #TOOL DATA



Notice

Adoption of new dynamic curve parameters can be deactivated by entering the logical axis number 0.

2.8.6 Thread drilling without compensating chuck (G63)

Syntax example of tapping in Z direction:

G63 Z.. F.. <spindle_name>..

modal

G63	Thread tapping
Z..	Thread depth (target point) in the tapping axis in [mm, inch]
F..	Feed rate in [mm/min, m/min, inch/min]
<spindle_name>..	Spindle speed consisting of spindle name according to P-CHAN-00053 and speed value in [rpm]

With this kind of tapping (G63) the position-controlled spindle is tracked by the CNC synchronously to the path motion. In this case the spindle and the feed motion of the participating axes are matched precisely and dynamically. A compensatory chuck is not required. The programmed feed rate must match the programmed spindle speed and the thread pitch and is calculated as follows:

Feed rate F [mm/min] = speed S [rpm] * pitch [mm/rev]

G63 is deselected by the selecting a different modal block type (e.g. linear motion G01). A non-modal block type (e.g. dwell time with G04) does not deactivate G63.

The path feed rate (F word) and spindle speed (S word) do not necessarily need to be specified in the same NC block as G63. The feed rate calculation must always be based on the last values programmed.

An error message is output if the path feed rate or spindle speed are equal to zero with G63 is selected.

M03, M04, M05, M19 cannot be programmed in combination with G331/G332.



Attention

The spindle (or the thread tapping drill) must be at standstill when G63 is selected. This can be achieved by previously programming M05 (Stop spindle) or M19 with S.POS (Position spindle).

Cutting a left-hand thread or movement out of a thread hole is programmed with a **negative S value**.

In C axis mode, the gear stage can be defined using the parameter P-AXIS-00052.



Programing Example

Tapping (G63)

Tap a right-hand thread with pitch 1.25 mm, thread depth 50 mm. At a programmed spindle speed S of 200 rpm the calculated feedrate is:

$$F = 200 * 1.25 = 250 \text{ mm/min}$$

```
;...
G01 F2000 G90 X0 Y0 Z0 ; position axes
M19 S.POS=0 M3 S100 ; stop and position spindle
;...
G63 Z-50 F250 S200 ; tap
      Z0 S-200 ; retract from threaded bore
G01 F1000 X100 ; reposition, deselect tapping
:
```



Programing Example

Tapping (G63)

```
%Tapping_G63

N05 X0 Y0 Z0
N10 G91 Z100
N20 M19 S.POS180 M3 S100 ; position spindle

N30 G63 Z-50 F300 S200 ; tap
N40 Z100 S-200 ; retract from threaded bore

N50 G01 X200 F3000 ; reposition, deselect tapping

N60 G63 Z-70 F300 S200 ; tap
N70 Z100 S-200 ; retract from threaded bore

N80 M05 G01 X300 F1000
N90 M30
```

A thread can also be executed in a rotating workpiece using G63 or G331/G332. The thread tapping drill feedrate results from the speed difference between the tool spindle and the driven thread tapping drill. Before starting the actual tapping, the spindle with the thread tapping drill must be coupled to the workpiece spindle at a synchronous speed. No spindle stop is required to start tapping or to establish the speed coupling. The process can be started on the fly both for the tool and the workpiece spindles.

2.8.7 Thread cutting with endlessly rotating spindle (G33)

Single-start/multi-start threads

When thread cutting with an endlessly rotating spindle (G33), the path motion is synchronised to the zero passage of the spindle rotation. Therefore, the thread can also be cut in several passes in succession. When an offset angle is specified as option, multi-start threads can also be produced.

To achieve a good machining result and to minimise path errors, feedforward control can be selected for the spindle and for path axes.

Programming

Syntax example for ZX plane (longitudinal axis Z, feed axis X):

G33 Z.. K.. [<spindle_name>.OFFSET=..] modal

G33	Thread cutting with endlessly rotating spindle. The G33 function is modal. The next motion block with a modal block type (G00, G01, G02, G03, spline, polynomial) deselects thread cutting.
Z..	Target point ("thread length") in [mm, inch]
K..	The thread pitch is programmed with active thread cutting in the unit [mm/rev, inch/rev] without a mathematical sign using the address letters I, J and K. They are assigned to the X, Y and Z axes according to DIN 66025. The thread pitch is modal up to program end and should not be zero on when G33 is selected. The feed is not programmed using the F word but results from the spindle speed and the thread pitch. The pitch of longitudinal or tapered threads at an inclination angle less than 45° is specified by the address letter K if the Z axis is the longitudinal turning axis. With facing or tapered threads with a pitch greater than or equal to 45°, the pitch is specified by I if the X axis is used as the face turning axis, and by J if the Y axis is used. The figure below shows examples for specifying thread pitch using the address letters in the Z-X plane.
<spindle_name>.OFFSET=..	Thread offset angle in [°] in spindle modulo range. Only required as an option for multi-turn threads. The offset angle is modal up to program end. Spindle name according to P-CHAN-00053. The "=" character is optional.

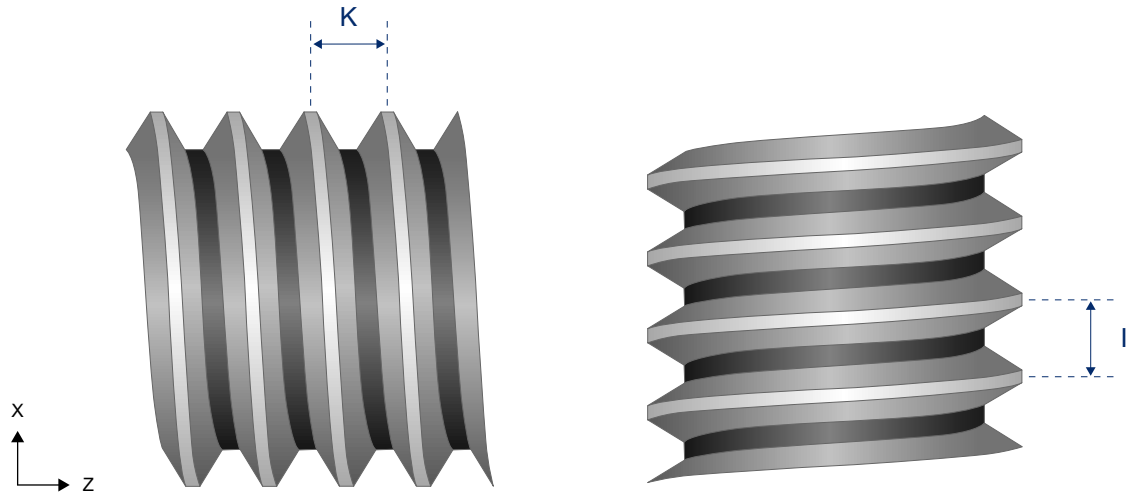
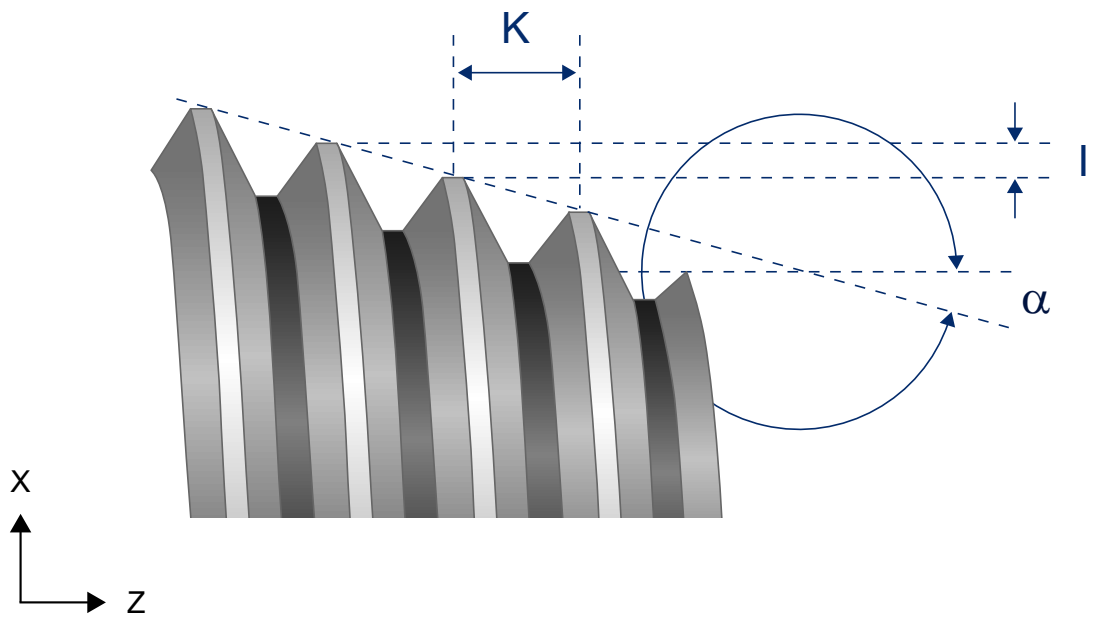
Pitch values I, K with longitudinal thread**Fig. 22: Value of thread pitch for longitudinal thread****Pitch values I, K with tapered thread****Fig. 23: Value of thread pitch for tapered thread**



Programming Example

Thread cutting with endlessly rotating spindle (G33)

G33 Z.. K.. [S.OFFSET=..]

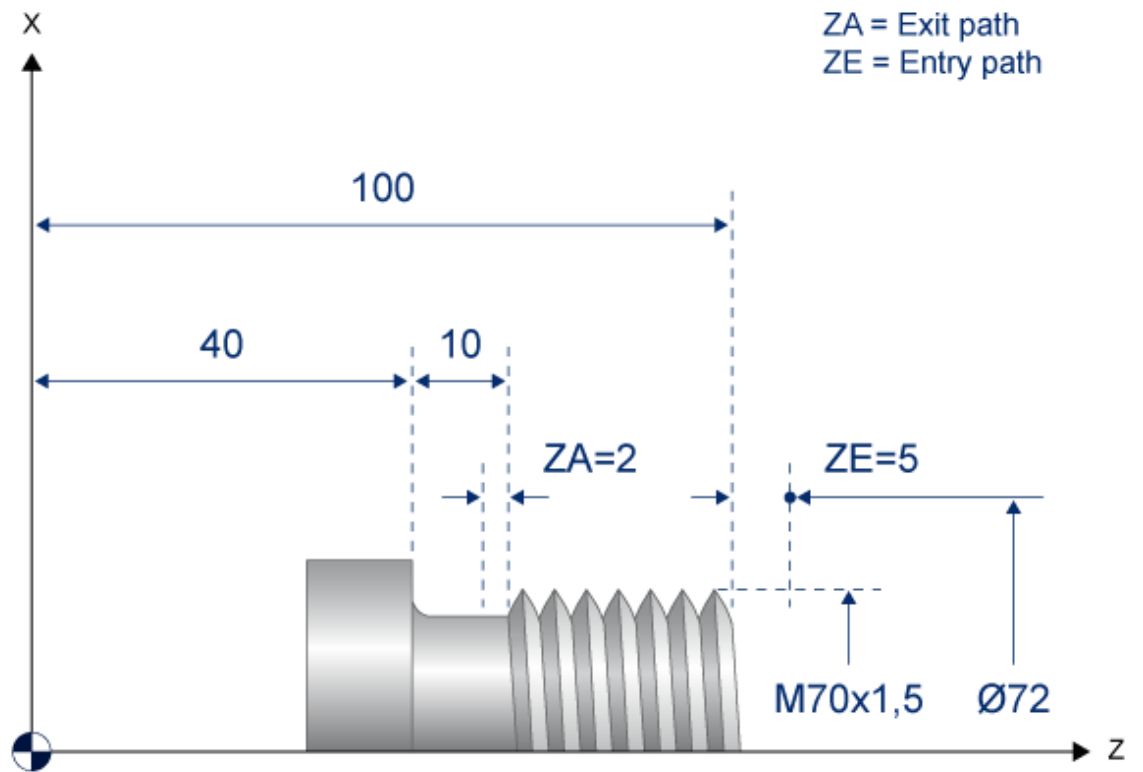

Fig. 24: Representation of geometry example

Cutting a longitudinal thread (M70x1.5) with several cuts:

```
%L longit_thread

N100 G33 Z48 K1.5 ;Cut thread turn
N110 G00 X72 ;Retract and move
N120 Z105 ;to start position
N130 M29 ;Subroutine end

%G33 (thread depth 0.92 mm)
N10 G51 ;Select diameter programming
N15 T1 D1 M03 S400 ;Select tool, start spindle
N20 G00 X72 Z105 ;Approach

N25 G01 X69.54 F1000 ;Position at 1st cutting depth
N30 LL longitudinal thread ;1st thread cut

N35 G01 X69.08 ;Position at 2nd cutting depth
N30 LL longitudinal thread ;2nd thread cut

N35 G01 X68.62 ;Position at 3rd cutting depth
N30 LL longitudinal thread ;3rd thread cut

N35 G01 X68.16 ;Position at final depth
N30 LL longitudinal thread ;4th thread cut

N35 G01 X68.16 ;Reposition at final depth
N30 LL longitudinal thread ;Empty cut

N60 M05 X150 Z200 ;Moving to end position
N65 M30 ;Program end
```

Cut a 2-turn longitudinal thread (M70x1.5)

```
%G33_2 (2-turn thread, thread depth 0.92 mm)
N10 G51 ;Select diameter programming
N15 T1 D1 M03 S40 ;Select tool, start spindle
N20 G00 X72 Z105 ;Approach
N25 G01 X68.16 F1000 ;Position at thread depth
N30 G33 Z48 K1.5 ;Cut 1st thread turn
N35 G00 X72 ;Retract and move
N40 Z105 ;to next
N45 G01 X68.16 ;start position
N50 G33 Z48 K1.5 S.OFFSET=180 ;Cut 2nd thread turn at 180°
N55 G00 X72 ;Retract and move
N60 M05 X150 Z200 ;to end position
N65 M30 ;Program end
```

Cutting a tapered thread

```
%L tapered thread
N010 G33 Z90 X1 I5.0           ;Cut thread turn (reference I)
; N010 G33 Z90 X1 K5.0       ;Cut thread turn (reference K)
N020 G00 X72                 ;Retract and move
N030 Z105                   ;to start position
N040 M29                     ;Subroutine end

%G33
N050 G00 X0 Y0 Z0
N060 G18
N070 G51                     ;Select diameter programming
N080 D1 M03 S1               ;Select tool, start spindle
N090 G00 X105 Z105          ;Start
N100 G01 X100 F1000         ;Position at 1st cutting depth
N110 LL tapered thread      ;1st thread cut
N120 M05 X150 Z200         ;Move to end position
N130 M30                     ;Program end
```

2.8.8 C-axis machining (face and lateral surface machining)

This functionality permits the face and lateral surface machining of cylindrical workpieces on machines with a rotary axis for workpiece mounting (e.g. lathes or milling machines with turntables). The workpiece is moved by the rotary axis or spindle (C axis) and the driven tool (e.g. a milling cutter) by the two translatory axes X (or Y) and Z.

The type of machine used for face machining is defined in the machine parameter P-CHAN-00008. The axis must be marked by the axis parameter P-AXIS-00015 as an axis for kinematic C axis transformation.

Facing and lateral surface machining can be described in Cartesian coordinates.

Spindle as channel axis

The main spindle is changed to a rotary path axis (e.g. "C").

Programming

#CAX [...]

#CAX OFF

Face machining

#FACE[...]

#FACE OFF

Lateral surface machining

#CYL

#CYL OFF

Parameter

P-CHAN-00008	The type of machine used for face machining
P-AXIS-00015	Axis mode for kinematic C axis transformation

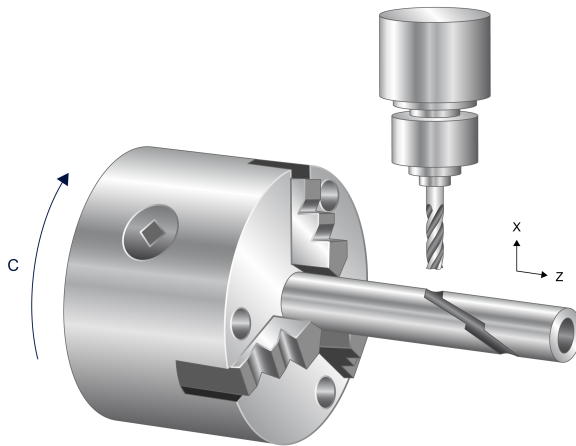

Fig. 25: Face and lateral surface machining

2.8.9 Turning functions

For a further description of turning functions, refer to the programming manual [PROG]

Cutter radius compensation

Tool tip radius compensation acts in the machining plane selected using G17, G18, G19. In this plane, one of the axes must be operated in "facing" mode and the other in "longitudinal turning" mode (P-AXIS-00015 (achs_mode)).

Programming

G40/G41/G42

Feedrate per revolution

During turning with active G95, a constant chip thickness can be defined with the F Word in mm/rev irrespective of spindle speed (rpm). Here, the axis feedrate is linked to the rotational speed (rpm) of the NC spindle.

Programming

G95

Constant cutting speed

To achieve a constant relative speed between the workpiece and the turning tool for all machining diameters during turning, the spindle speed is coupled to the distance of the feed axis from the turning centre.

Programming

G96, G97, G196

2.9 HLI interface objects (NCK PLC interface)

For a description of the spindle-specific data available at the PLC interface, refer to the separate documentation entitled "HLI interface" [HLI].

Overview

Speeds

- Nominal speed
- Actual speed
- Speed programmed

Positions

- Target position
- Actual position

Status information

- Operating state
- Speed monitoring active
- Nominal speed reached
- Spindle stopped
- Speed monitoring invalid
- Distance to go
- Job error

Control commands

- Spindle stop at program end
- Spindle reset

External spindle command

Everything that can be commanded via the channel can also be commanded via the external interface.

3 Parameter

3.1 Overview of channel, axis and tool parameters

ID	Parameter	Description
P-CHAN-00004	autom_range	Automatic gear speed change
P-CHAN-00007	bezeichnung	Spindle designation
P-CHAN-00008	cax_face_id	Face machining variant (turning/milling)
P-CHAN-00010	de-fault_ax_name_of_spindle	Name of the spindle as channel axis
P-CHAN-00036	log_achs_nr	Spindle axis number
P-CHAN-00037	log_achs_nr_master	Master axis
P-CHAN-00038	log_achs_nr_slave	slave axis
P-CHAN-00043	m19_synch	Synchronisation type of the M19 function
P-CHAN-00045	m3_synch	Synchronisation type of the M03 function
P-CHAN-00047	m4_synch	Synchronisation type of the M04 function
P-CHAN-00049	m5_synch	Synchronisation type of the M05 function
P-CHAN-00051	main_spindle_ax_nr	Definition of Main Spindle
P-CHAN-00052	main_spindle_gear_change	Enabling gear changes
P-CHAN-00053	main_spindle_name	Main spindle designation
P-CHAN-00055	max_speed	Speed range limits
P-CHAN-00058	min_speed	Speed range limits
P-CHAN-00061	mode	Coupling mode
P-CHAN-00069	plc_control	PLC-controlled spindle via channel interface
P-CHAN-00074	range_way	Search direction in the speed range table
P-CHAN-00081	s_synch	Synchronisation method of the S function
P-CHAN-00082	spdl_anzahl	Number of spindles in the channel

ID	Parameter	Description
P-AXIS-00007	a_konst	Constant acceleration
P-AXIS-00010	a_min	Acceleration minimum
P-AXIS-00015	achs_mode	Axis mode
P-AXIS-00016	achs_nr	axis number
P-AXIS-00018	achs_typ	Axis type
P-AXIS-00020	antr_typ	Drive type
P-AXIS-00026	b1	Coefficient
P-AXIS-00027	b2	Coefficient
P-AXIS-00028	b3	Coefficient
P-AXIS-00031	beweg_richt	Direction of rotation for rotary axes
P-AXIS-00041	n1	Speed limit 1 for maximum torque
P-AXIS-00078	getr_schalt_pos	Gear speed change position
P-AXIS-00079	getriebe_stufe	Number of default gear speed
P-AXIS-00099	kv	Proportional factor kv for P-positional control
P-AXIS-00120	mod_komp	Activation of modulo compensation
P-AXIS-00124	modulo_fehler	Modulo error compensation
P-AXIS-00125	modulo_umdreh	Number of revolutions
P-AXIS-00126	moduloo	Upper modulo range limit
P-AXIS-00127	modulou	Lower modulo range limit
P-AXIS-00128	multi_gain_n	Adjustment of the drive manipulated variable to the D/A converter
P-AXIS-00129	multi_gain_z	Adjustment of the drive manipulated variable to the D/A converter
P-AXIS-00130	n_grenz	Limit speed
P-AXIS-00156	ref_ohne_nocken	Referencing without cam
P-AXIS-00157	ref_ohne_rev	Referencing without reversal
P-AXIS-00159	reverse	Nominal/actual sign reversal in the position controller at +/- 10 V
P-AXIS-00202	typ	Curve type
P-AXIS-00205	v_reso_denom	Speed scaling denominator
P-AXIS-00206	v_reso_num	Speed scaling nominator
P-AXIS-00207	v_time_base	Timebase for speed scaling
P-AXIS-00209	vb_eilgang	Rapid traverse velocity
P-AXIS-00216	vb_min_null	Limit for speed == 0 for speed monitoring
P-AXIS-00217	vb_prozent	Factor for spindle speed reached
P-AXIS-00220	vb_regelgrenze	Speed for control limit

P-AXIS-00224	vorz_richtung	Restriction of direction of rotation for rotary axes
P-AXIS-00233	wegaufn	Distance resolution of measuring system
P-AXIS-00234	wegaufz	Distance resolution of measuring system
P-AXIS-00240	a_max	Maximum spindle acceleration
P-AXIS-00242	n2	Speed limit 2 for maximum output
P-AXIS-00265	velocity_position_control_on	Changeover speed
P-AXIS-00266	velocity_position_control_off	Switch back speed

ID	Parameter	Description
P-TOOL-00012	log_ax_nr_spdl	Logical axis number of the spindle
P-TOOL-00013	vb_min	Minimum speed
P-TOOL-00014	vb_max	Maximum speed
P-TOOL-00015	a_max	Maximum acceleration

3.2 Description

3.2.1 Channel parameters

Overview

This chapter describes the channel-specific parameter for configuring spindles. Note that only the spindles entered in the channel parameter list can also be addressed in the part program. This applies to both NC and PLC spindles.

The spindle configuration defined in the channel parameter list is the default assignment which is provided after the controller is started up.

P-CHAN-00082	Number of configured spindles in NC channel
Description	This element specifies the total number of existing position-controlled and speed-controlled spindles. The number of spindles must be identical with the entered spindles (spindel[i].*).
Parameter	spdl_anzahl
Data type	UNS16
Data range	$0 \leq \text{spdl_anzahl} \leq 6$ (application-specific)
Dimension	----
Default value	0
Remarks	Parameterisation example: A position-controlled and a speed-controlled spindle are to be configured. <i>spdl_anzahl 2</i>

P-CHAN-00010	Spindle name within a path compound
Description	If a spindle axis is changed with specific machining modes (e.g. C axis mode) in the path compound, it can be addressed by this default name (e.g. C1).
Parameter	default_ax_name_of_spindle
Data type	STRING
Data range	Maximum 16 characters (length of spindle designation, application-specific)
Dimension	----
Default value	*
Remarks	The designation of spindles in the path compound must start with the letters A, B, C, U, V, W, X, Y, Z or Q. After that, all letters and digits are possible. The axis designation must be unique. It may not be identical with the configured name of a channel axis (P-CHAN-00006). Parameterisation example: The C axis receives the designation C1. <i>default_ax_name_of_spindle C1</i> * Note: The default value of variables is a blank string.

P-CHAN-00051	Logical axis number of the main spindle in the NC channel
Description	This parameter assigns the definition of the main spindle. The logical axis number of one of the spindles which is configured in the channel parameters list is entered here. After the controller starts up, this spindle becomes the main spindle. However, any other spindle in the system can be declared to be the main spindle using a command in the part program (#MAIN SPINDLE [PROG]).
Parameter	main_spindle_ax_nr
Data type	UNS16
Data range	1 ... MAX(UNS16)
Dimension	----
Default value	0
Remarks	Parameterisation example: The spindle with logical axis number 6 is the main spindle. <i>main_spindle_ax_nr 6</i>

P-CHAN-00053	Designation of the main spindle in the NC channel
Description	Besides the logical axis number, a name must be assigned to the main spindle by which it can be addressed in the subroutine. This parameter therefore assigns an axis name to the main spindle. The axis name is freely selectable, but the first character must be an 'S'.
Parameter	main_spindle_name
Data type	STRING
Data range	Maximum 16 characters (length of spindle designation, application-specific)
Dimension	----
Default value	*
Remarks	The designation of the main spindle cannot be changed in the subroutine. However, if the main spindle is changed using #MAIN SPINDLE (see [PROG]), the new main spindle is assigned. Parameterisation example: The main spindle (logical axis number 6) is programmed in the subroutine with the name 'S'. <i>main_spindle_ax_nr 6</i> main_spindle_name S * Note: The default value of variables is a blank string.

P-CHAN-00008	Machine ID with C axis face machining
Description	This parameter defines the type of machine used for face machining.
Parameter	<code>cax_face_id</code>
Data type	UNS16
Data range	1: Lathe (automatic orientation of the rotary axis in the centre of rotation) 2: Milling machines (no orientation)
Dimension	----
Default value	0
Remarks	Parameterisation example: Face machining takes place on a milling machine. <code>cax_face_id 2</code>

P-CHAN-00036	Logical axis number of a spindle in NC channel
Description	The logical axis number is entered in this parameter. The logical axis name is unique throughout the entire system. The logical axis number assigns the spindle name in the NC program to the axis data (see axis parameters lists in [AXIS]). Therefore only logical numbers make sense if they are known to the NC program. The logical axis number "0" is not permitted.
Parameter	<code>spindel[i].log_achs_nr</code>
Data type	UNS16
Data range	1... MAX(UNS16)
Dimension	----
Default value	-
Remarks	A logical axis number may not be assigned several times. A logical axis number may not be simultaneously configured as path axis and spindle. If this is the case, the plausibility check of the channel parameters generates an error message at start-up.

P-CHAN-00007	Name of a spindle in the NC channel
Description	This parameter defines the default name to address the spindle in the NC program. Please note that as long as a spindle is the main spindle, it can only be programmed using the main spindle name. The spindle name is a string.
Parameter	spindel[i].bezeichnung
Data type	STRING
Data range	Maximum 16 characters (length of spindle designation, application-specific)
Dimension	----
Default value	*
Remarks	<p>The spindle names must start with the letter 'S'. After that, all letters and digits are possible. Spindle names must be unique.</p> <p>Parameterisation example: Configuration of a 1-channel system with 3 spindles. After start-up, spindle 'S1' with logical axis number 6 is the main spindle. It is addressed by the spindle name 'S'. The spindles with logical axis numbers 11 and 30 are programmed by their default names 'S2' and 'S3'.</p> <pre> spd1_anzahl 3 : main_spindle_ax_nr 6-> -> ->- main_spindle_name S ->- / # / / spindel[0].bezeichnung S1-<- / spindel[0].log_achs_nr 6-< -< -<- : spindel[1].bezeichnung S2 spindel[1].log_achs_nr 11 : spindel[2].bezeichnung S3 spindel[2].log_achs_nr 30 * Note: The default value of variables is a blank string. </pre>

P-CHAN-00069	Spindle control by PLC via channel specific interface
Description	This parameter is set to TRUE if a spindle is controlled directly by the PLC and not by a spindle interpolator in the NC channel. Note here that all synchronisations are no longer (spindle) axis-specific but are output and processed by the channel-specific HLI range. The axis-specific syntax for programming spindle commands is still allowed, but is limited to specifying the speed and the M functions M3/M4/M5/M19.
Parameter	spindel[i].plc_control
Data type	BOOLEAN
Data range	0/1
Dimension	----
Default value	0
Remarks	

Synchronisation definitions

P-CHAN-00081	Synchronisation type of the spindle S function
Description	This parameter defines the synchronisation type of the spindle S function. The synchronisation type is defined as a string constant or a hexadecimal value.
Parameter	spindel[i].s_synch
Data type	STRING
Data range	See Spindle-specific synchronisation types
Dimension	----
Default value	NO_SYNCH
Remarks	<p>Parameterisation example: For a (position-controlled) spindle 'S1' the spindle function is executed without synchronisation. The PLC is not informed.</p> <pre> spindel[0].bezeichnung S1 spindle[0].log_achs_no 6 spindel[0].s_synch MOS 0x00000001 spindle[0].m3_synch PLC_INFO MVS_SVS 0x00020002 spindle[0].m4_synch PLC_INFO MVS_SNS 0x00020004 spindle[0].m5_synch PLC_INFO MVS_SVS 0x00020002 spindle[0].m19_synch MNS_SNS 0x00000008 </pre> <p>Note: Programming a UNS32 variable is permissible for downward compatibility reasons. Example: spindel[0].s_synch 0x00000001</p>

P-CHAN-00045	Synchronisation type for M03
Description	When the M03 function is used, the synchronisation type must be defined for the spindles used. The synchronisation type is defined as a string constant or a hexadecimal value.
Parameter	spindel[i].m3_synch
Data type	STRING
Data range	See Spindle-specific synchronisation types
Dimension	----
Default value	NO_SYNCH
Remarks	<p>Parameterisation example: For a (position-controlled) spindle 'S1', the spindle-specific M function M03 is assigned the synchronisation type MVS_SVS. The PLC is also informed.</p> <pre> spindel[0].bezeichnung S1 spindle[0].log_achs_no 6 spindel[0].s_synch MOS 0x00000001 spindel[0].m3_synch PLC_INFO MVS_SVS 0x00020002 spindle[0].m4_synch PLC_INFO MVS_SNS 0x00020004 spindle[0].m5_synch PLC_INFO MVS_SVS 0x00020002 spindle[0].m19_synch MNS_SNS 0x00000008 </pre> <p>Note: Programming a UNS32 variable is permissible for downward compatibility reasons. Example: spindel[0].m3_synch 0x00020002</p>

P-CHAN-00047	Synchronisation type for M04
Description	When the M04 function is used, the synchronisation type must be defined for the spindles used. The synchronisation type is defined as a string constant or a hexadecimal value.
Parameter	spindel[i].m4_synch
Data type	STRING
Data range	See Spindle-specific synchronisation types
Dimension	----
Default value	NO_SYNCH
Remarks	<p>Parameterisation example: For a (position-controlled) spindle 'S1' the spindle-specific M function M04 is assigned the synchronisation type MVS_SNS. The PLC is also informed.</p> <pre> spindel[0].bezeichnung S1 spindel[0].log_achs_no 6 spindel[0].s_synch MOS 0x00000001 spindel[0].m3_synch PLC_INFO MVS_SVS 0x00020002 spindel[0].m4_synch PLC_INFO MVS_SNS 0x00020004 spindel[0].m5_synch PLC_INFO MVS_SVS 0x00020002 spindel[0].m19_synch MNS_SNS 0x00000008 </pre> <p>Note: Programming a UNS32 variable is permissible for downward compatibility reasons. Example: spindel[0].m4_synch 0x00020004</p>

P-CHAN-00049	Synchronisation type for M05
Description	When the M05 function is used, the synchronisation type must be defined for the spindles used. The synchronisation type is defined as a string constant or a hexadecimal value.
Parameter	spindel[i].m5_synch
Data type	STRING
Data range	See Spindle-specific synchronisation types
Dimension	----
Default value	NO_SYNCH
Remarks	<p>Parameterisation example: For a (position-controlled) spindle 'S1', the spindle-specific M function M05 is assigned the synchronisation type MVS_SVS. The PLC is also informed.</p> <pre> spindel[0].bezeichnung S1 spindel[0].log_achs_no 6 spindel[0].s_synch MOS 0x00000001 spindel[0].m3_synch PLC_INFO MVS_SVS 0x00020002 spindel[0].m4_synch PLC_INFO MVS_SNS 0x00020004 spindel[0].m5_synch PLC_INFO MVS_SVS 0x00020002 spindel[0].m19_synch MNS_SNS 0x00000008 </pre> <p>Note: Programming a UNS32 variable is permissible for downward compatibility reasons. Example: spindel[0].m5_synch 0x00020002</p>

P-CHAN-00043	Synchronisation type for M19
Description	When the M19 function is used, the synchronisation type must be defined for the spindles used. The synchronisation type is defined as a string constant or a hexadecimal value.
Parameter	spindel[i].m19_synch
Data type	STRING
Data range	See Spindle-specific synchronisation types
Dimension	----
Default value	NO_SYNCH
Remarks	<p>Parameterisation example: For a (position-controlled) spindle 'S1' the spindle-specific M function M19 is assigned the synchronisation type MNS_SNS. The PLC is also informed.</p> <pre> spindel[0].bezeichnung S1 spindle[0].log_achs_no 6 spindel[0].s_synch MOS 0x00000001 spindel[0].m3_synch PLC_INFO MVS_SVS 0x00020002 spindle[0].m4_synch PLC_INFO MVS_SNS 0x00020004 spindle[0].m5_synch PLC_INFO MVS_SVS 0x00020002 spindel[0].m19_synch MNS_SNS 0x00000008 </pre> <p>Note: Programming a UNS32 variable is permissible for downward compatibility reasons. Example: spindel[0].m19_synch 0x00000008</p>

Gear change

Gear changing is only possible for the main spindle

P-CHAN-00052	Enable mechanical gear change of main spindle
Description	This parameter enables or disables gear changes for the main spindle.
Parameter	main_spindle_gear_change
Data type	BOOLEAN
Data range	0: Spindle gear changes disabled for the main spindle 1: Spindle gear changes enabled for the main spindle
Dimension	----
Default value	0
Remarks	The M functions to select the gear speeds of the main spindle M40–45 are activated by the parameter P-CHAN-00052 in the channel parameter list. The M functions M40–45 can be freely used if gear changes are disabled.

P-CHAN-00074	Direction of range selection for spindle gear change
Description	This parameter defines whether the lower or the higher gear range is selected when speed ranges overlap. If 'range_way' = 0 the search starts from the lowest speed range, if 'range_way' > 0 from the highest. The correct speed (gear) range is the one where the programmed spindle speed is first found.
Parameter	spindel[i].range_way
Data type	UNS16
Data range	$0 \leq \text{range_way} < \text{MAX}(\text{UNS16})$
Dimension	----
Default value	0
Remarks	Parameterisation example: The search starts from the lowest speed range. <i>spindel[0].range_way 0 (from bottom to top)</i>

P-CHAN-00004	Automatic range selection for spindle gear change
Description	If the spindle gear range is to be automatically determined by the NC kernel, this parameter must be set to 1. In this case the M functions M40 to M45 need not be programmed. This means that the correct gear range is determined implicitly by the programmed speed (S word).
Parameter	spindel[i].autom_range
Data type	BOOLEAN
Data range	0/1
Dimension	----
Default value	0
Remarks	Parameterisation example: The automatic range selection is enabled. <i>spindel[0].autom_range 1</i>

P-CHAN-00058	Minimum spindle speed of a speed range (spindle gear change)
Description	The speed ranges of a spindle may be defined with or without overlap. If one range is not used, the corresponding values must be set to zero in the table.
Parameter	spindel[i].range_table[j].min_speed
Data type	UNS16
Data range	$0 \leq \text{min_speed} \leq \text{MAX}(\text{UNS16})$
Dimension	rpm
Default value	0
Remarks	<p>Parameterisation example: Definition of a speed range table for 6 ranges. Only the first four ranges are used.</p> <pre> spindel[0].range_table[0].min_speed 50 spindel[0].range_table[0].max_speed 560 spindel[0].range_table[1].min_speed 400 spindel[0].range_table[1].max_speed 800 spindel[0].range_table[2].min_speed 700 spindel[0].range_table[2].max_speed 3360 spindel[0].range_table[3].min_speed 3361 spindel[0].range_table[3].max_speed 4000 spindel[0].range_table[4].min_speed 0 spindel[0].range_table[4].max_speed 0 spindel[0].range_table[5].min_speed 0 spindel[0].range_table[5].max_speed 0 </pre>

P-CHAN-00055	Maximum spindle speed of a speed range (spindle gear change)
Description	The speed ranges of a spindle may be defined with or without overlap. If one range is not used, the corresponding values must be set to zero in the table.
Parameter	spindel[i].range_table[j].max_speed
Data type	UNS16
Data range	$0 \leq \text{max_speed} \leq \text{MAX}(\text{UNS16})$
Dimension	rpm
Default value	0
Remarks	<p>Parameterisation example: Definition of a speed range table for 6 ranges. Only the first four ranges are used.</p> <pre> spindel[0].range_table[0].min_speed 50 spindel[0].range_table[0].max_speed 560 spindel[0].range_table[1].min_speed 400 spindel[0].range_table[1].max_speed 800 spindel[0].range_table[2].min_speed 700 spindel[0].range_table[2].max_speed 3360 spindel[0].range_table[3].min_speed 3361 spindel[0].range_table[3].max_speed 4000 spindel[0].range_table[4].min_speed 0 spindel[0].range_table[4].max_speed 0 spindel[0].range_table[5].min_speed 0 spindel[0].range_table[5].max_speed 0 </pre>

Synchronous operation

P-CHAN-00038	Logical axis number of the slave axis (synchronous operation)
Description	This parameter defines an axis as the slave axis. The logical axis number P-CHAN-00035 must then be specified.
Parameter	<code>synchro_data.koppel_gruppe[i].paar[j].log_achs_nr_slave</code>
Data type	UNS16
Data range	1 ... MAX(UNS16)
Dimension	----
Default value	0
Remarks	Parameterisation example: The axis with the logical number 3 is defined in the coupled axis pair[1] within the coupled axis group[0] as slave axis. <i><code>synchro_data.koppel_gruppe[0].paar[1].log_achs_nr_slave 3</code></i>

P-CHAN-00037	Logical axis number of the master axis (synchronous operation)
Description	This parameter defines an axis as the master axis. The logical axis number P-CHAN-00035 must then be specified.
Parameter	<code>synchro_data.koppel_gruppe[i].paar[j].log_achs_nr_master</code>
Data type	UNS16
Data range	1 ... MAX(UNS16)
Dimension	----
Default value	0
Remarks	Parameterisation example: The axis with the logical number 1 is defined in the coupled axis pair[1] within the coupled axis group[0] as the master axis. <i><code>synchro_data.koppel_gruppe[0].paar[1].log_achs_nr_master 1</code></i>

P-CHAN-00061	Mode of the coupled axis pair (synchronous operation)
Description	Since spindle axes can be coupled in addition to the synchronous operation of path axes, the type of coupling must be specified for each pair. The coupling type must therefore be entered in this parameter.
Parameter	synchro_data.koppel_gruppe[i].paar[j].mode
Data type	UNS16
Data range	0: Coupled axis pair consists of path axes 1: Coupled axis pair consists of spindle axes
Dimension	----
Default value	0
Remarks	<p>Parameterisation example:</p> <p>The coupled axis pair [0] within the coupled axis group [0] consists of path axes (mode 0) The coupled axis pair [1] within the coupled axis group [0] consists of spindle axes (mode 1).</p> <pre>#synchro_data.koppel_gruppe[0].paar[0].log_achs_nr_slave 4 #synchro_data.koppel_gruppe[0].paar[0].log_achs_nr_master 1 #synchro_data.koppel_gruppe[0].paar[0].mode 0 #synchro_data.koppel_gruppe[0].paar[1].log_achs_nr_slave 11 #synchro_data.koppel_gruppe[0].paar[1].log_achs_nr_master 6 #synchro_data.koppel_gruppe[0].paar[1].mode 1</pre>

3.2.2 Axis parameters

Overview

Only the specific parameters for spindle axes are described here. Refer to the [AXIS] documentation for details on further parameters available for setting axes.

P-AXIS-00015	Axis mode	
Description	Axes can be traversed in different operating modes.	
Parameter	kenngr.achs_mode	
Data type	UNS32	
Data range	0x00000001 - 0x10000000	
Axis types	T, R, S	
Dimension	T: ----	R,S: ----
Default value	0x00000001	
Drive types	----	
Remarks		

P-AXIS-00016	Logical axis number	
Description	The logical axis number is a system-wide unique identifier for each axis. The entire management of axis data in the NC kernel takes place using the logical axis number.	
Parameter	kopf.achs_nr	
Data type	UNS16	
Data range	0 < achs_nr < MAX(UNS16)	
Axis types	T, R, S	
Dimension	T: ----	R,S: ----
Default value	1	
drive types.	----	
Remarks	<p>It is not allowed to use the same logical axis number more than once. The logical axis number "0" is not allowed.</p> <p>The assignment of an axis designation in the NC program to a logical axis (axis number) takes place in the channel parameters [CHAN].</p> <p>This entry is not adopted when the axis parameter list is updated. Updates only become effective when the controller is rebooted.</p>	

P-AXIS-00018	Axis type (linear axis, rotary axes, spindle)	
Description	This parameter specifies the axis type of an axis.	
Parameter	kenngr.achs_typ	
Data type	STRING	
Data range	Linear axis (ACHSTYP_TRANSLATOR) : 0x0001 Rotary axis (ACHSTYP_ROTATOR) : 0x0002 Spindle (ACHSTYP_SPINDEL): : 0x0004	
Axis types	T, R, S	
Dimension	T: ----	R,S: ----
Default value	ACHSTYP_TRANSLATOR	
Drive types	----	
Remarks	Depending on the axis type that is set, special functionalities are addressed in the NC kernel. Examples: - modulo calculation for rotary axes, - speed monitoring for spindles	

P-AXIS-00020	Drive type	
Description	This parameter defines the drive type for each axis. A choice of drive types can be made for each axis:	
Parameter	kenngr.antr_typ	
Data type	UNS16	
Data range	1 : Conventional drive interface 2 : SERCOS drive interface 3 : PROFIDRIVE MC drive interface 4 : Drive simulation 5 : Beckhoff Lightbus drive interface 6 : Drive interface +-10V over field bus (terminal) 7 : RT Ethernet drive interface 8 : CANopen drive interface 16 : Virtual axis 32 : CAN bus	
Axis types	T, R, S	
Dimension	T: ----	R,S: ----
Default value	0x0004	
Drive types	----	
Remarks	This entry is not adopted when the axis parameter list is updated. Updates only become effective when the controller is rebooted. Axis parameter block data can be divided into drive type dependent and drive type independent parameters.	

P-AXIS-00159	Reverse of sign for setpoint and actual value	
Description	The turning direction of a spindle is defined in this parameter. If reverse is TRUE, the signs of the output and input data are changed. This is an option for keeping the signs of setpoint and actual values.	
Parameter	getriebe[i].reverse	
Data type	BOOLEAN	
Data range	0/1	
Axis types	S	
Dimension		S: ----
Default value	0	
Drive types	Simulation, Conventional, Terminal, Lightbus, Profidrive	
Remarks		

P-AXIS-00234	Distance resolution of measurement (numerator)	
Description	The distance resolution of the measuring system is entered in the dimension [increment/0.1 μm] for translatory axes or [increment/0.0001°] for rotary axes. The number of increments must be entered in 'getriebe[i].wegaufz' (numerator), the size of the motion path in [0.1 μm] for translatory axes or in [0.0001°] for rotary axes in 'getriebe[i].wegaufn' (denominator).	
Parameter	getriebe[i].wegaufz	
Data type	UNS32	
Data range	1 ≤ wegaufz ≤ MAX(UNS32)	
Axis types	T, R, S	
Dimension	T: increments	R,S: increments
Default value	1	
Drive types	----	
Remarks	<p>These entries are not taken over when the axis parameter list is updated. A controller reboot is required to update.</p> <p>Note that when a distance resolution is greater than 1, the motion range is restricted to less than (-MAX(UNS32)... +MAX(UNS32)) [μm/10⁻³°].</p> <p>If wegaufz is 0, the CNC generates the warning 110386 and corrects the parameter to the value 1.</p> <p>If P-AXIS-00234/ P-AXIS-00233 are used, the parameters P-AXIS-00362 and P-AXIS-00363 must be set to 1.</p> <p>Recommendation: It is recommended to set the path resolution using the parameters P-AXIS-00362 and P-AXIS-00363 .</p> <p>For possible applications, see Settings of position scaling</p>	

P-AXIS-00233	Distance resolution of measurement (denominator)	
Description	The distance resolution of the measuring system is entered in the dimension [increment/0.1 µm] for translatory axes or [increment/0.0001°] for rotary axes. The number of increments must be entered in 'getriebe[i].wegaufz' (numerator), the size of the motion path in [0.1 µm] for translatory axes or in [0.0001°] for rotary axes in 'getriebe[i].wegaufn' (denominator).	
Parameter	getriebe[i].wegaufn	
Data type	UNS32	
Data range	1 ≤ wegaufn ≤ MAX(UNS32)	
Axis types	T, R, S	
Dimension	T: 0.1 µm	R,S: 0.0001°
Default value	1	
Drive types	----	
Remarks	<p>These entries are not adopted when updating the axis parameter list. For updating to take effect, the control system must be restarted.</p> <p>Note that when a distance resolution is greater than 1, the motion range is restricted to less than (-MAX(UNS32)... +MAX(UNS32)) [µm/10⁻³°].</p> <p>If wegaufn is 0, the CNC generates the warning 110086 and corrects the parameter to the value 1.</p> <p>If P-AXIS-00234/ P-AXIS-00233 are used, the parameters P-AXIS-00362 and P-AXIS-00363 must be set to 1.</p> <p>Recommendation: It is recommended to set the path resolution using the parameters P-AXIS-00362 and P-AXIS-00363 .</p> <p>For possible applications, see Settings of position scaling</p>	

P-AXIS-00129	Adaptation of command value of drive to the drive format (numerator)	
Description	<p>The speed setpoint calculated in the position controller must be adapted to the D/A format of the D/A converter. The digital value at the D/A converter input (getriebe[i].multi_gain_z/ getriebe[i].mult_gain_n) must be specified at which the axis travels at the velocity of [1m/min] or at the speed [1000°/min].</p> <p>Denominator : P-AXIS-00128</p>	
Parameter	getriebe[i].multi_gain_z	
Data type	UNS32	
Data range	1 ≤ multi_gain_z ≤ MAX(UNS32)	
Axis types	T, R, S	
Dimension	T: Bit	R,S: Bit
Default value	2000	
Drive types	Simulation, Conventional, Terminal, Lightbus, Profidrive	
Remarks		

P-AXIS-00128	Adapting the drive command value to the drive format (denominator)	
Description	The speed setpoint calculated in the position controller must be adapted to the D/A format of the D/A converter. The digital value at the D/A converter input (getriebe[i].multi_gain_z/getriebe[i].mult_gain_n) must be specified at which the axis travels at the velocity of [1m/min] or at the speed [1000°/min]. Numerator: P-AXIS-00129	
Parameter	getriebe[i].multi_gain_n	
Data type	UNS32	
Data range	$1 \leq \text{multi_gain_n} \leq \text{MAX(UNS32)}$	
Axis types	T, R, S	
Dimension	T: ----	R,S: ----
Default value	1	
Drive types	Simulation, Conventional, Terminal, Lightbus, Profidrive	
Remarks		

P-AXIS-00099	Proportional factor kv for P-positional control	
Description	The P-positional controller has the amplification factor k_v . The parameter is only effective if the CNC internal position control is used. With drive amplifiers with integrated position control, the amplification must be defined in the drive. The parameter P-AXIS-00320 determines the manner how an axis moves to its commanded position.	
Parameter	getriebe[i].kv	
Data type	UNS32	
Data range	$0 < k_v \leq \text{MAX(UNS32)}$	
Axis types	T, R, S	
Dimension	T: 0.01/s	R,S: 0.01/s
Default value	1000	
Drive types	----	
Remarks		

Settings for modulo calculation

P-AXIS-00126	Upper modulo limit	
Description	For modulo calculation for rotary axes, an upper modulo limit' (e.g. 360°) should be set.	
Parameter	getriebe[i].moduloo	
Data type	SGN32	
Data range	modulou < moduloo ≤ MAX(SGN32)	
Axis types	R, S	
Dimension		R,S: 0.0001°
Default value	3600000	
Drive types	----	
Remarks	Modulo calculation is activated automatically for rotary axes and spindles (axis types 0x2 and 0x4).	

P-AXIS-00127	Lower modulo limit	
Description	For modulo calculation for rotary axes, a lower modulo limit (e.g. 0°) should be set.	
Parameter	getriebe[i].modulou	
Data type	SGN32	
Data range	MIN(SGN32) ≤ modulou < moduloo	
Axis types	R, S	
Dimension		R,S: 0.0001°
Default value	0	
Drive types	----	
Remarks	Modulo calculation is activated automatically for rotary axes and spindles (axis types 0x2 and 0x4).	

P-AXIS-00125	Number of rotations in case of modulo error compensation	
Description	When a rotary axis is operated, in certain circumstances the modulo circle of the command variables cannot be converted to the modulo circle of the increments without errors. The modulo circle of the increments is less by the rounding error. This is compensated by the modulo compensation in the position controller so that the missing increments per modulo rotation can be preset as integers in the machine data P-AXIS-00124 .	
Parameter	getriebe[i].modulo_umdreh	
Data type	SGN16	
Data range	$0 \leq \text{modulo_umdreh} \leq \text{MAX}(\text{SGN16})$	
Axis types	R, S	
Dimension		R,S: ----
Default value	0	
Drive types	Simulation, Conventional, Terminal, Lightbus, Profidrive	
Remarks	This function is activated via the parameter P-AXIS-00120.	

P-AXIS-00124	Error in modulo circle	
Description	See also P-AXIS-00125	
Parameter	getriebe[i].modulo_fehler	
Data type	SGN16	
Data range	MIN(SGN16) ... MAX(SGN16)	
Axis types	R, S	
Dimension		R,S: increments
Default value	0	
Drive types	Simulation, Conventional, Terminal, Lightbus, Profidrive	
Remarks		

P-AXIS-00120	Activation of modulo compensation	
Description	This parameter activates the modulo compensation in position controller.	
Parameter	lr_param.mod_komp	
Data type	BOOLEAN	
Data range	0/1	
Axis types	R, S	
Dimension		R,S: ----
Default value	0	
Drive types	----	
Remarks		

Speeds and velocities

P-AXIS-00220	Limiting velocity for the measurement system	
Description	Especially with spindles, the limit at which the measuring system supplies erroneous signals at higher rotation speeds can be exceeded. The parameter describes the velocity value at which the position controller has to switch over to open-loop controlled operation mode.	
Parameter	getriebe[i].vb_regelgrenze	
Data type	UNS32	
Data range	$0 \leq vb_regelgrenze \leq \text{MAX}(\text{UNS32})$	
Axis types	S	
Dimension		S: 0.001°/s
Default value	200000	
drive types.	Simulation, Conventional, Terminal, Lightbus, Profidrive	
Remarks		

P-AXIS-00216	Limit for spindle speed 'zero'	
Description	Especially in the case of spindles, the barrier should be given below which rotational speed monitoring in the position controller shows the state 'speed zero'.	
Parameter	getriebe[i].vb_min_null	
Data type	UNS32	
Data range	$0 \leq vb_min_null \leq \text{MAX}(\text{UNS32})$	
Axis types	S	
Dimension		S: 0.001°/s
Default value	100	
drive types.	----	
Remarks		

P-AXIS-00217	Speed-value attained - tolerance band	
Description	This parameter defines the actual speed value at which the status 'speed-value attained' is declared.	
Parameter	kenngr.vb_prozent	
Data type	UNS16	
Data range	0 ... 1000	
Axis types	S	
Dimension		S: 0.1%
Default value	100	
Drive types	----	
Remarks	Configuration example: For 'kenngr.vb_prozent = 100' the message 'speed-value attained' appears when '1.1 * commanded speed ≥ actual speed-value ≥ 0.9 * commanded speed '.	

P-AXIS-00209	Rapid mode velocity	
Description	The rapid traverse velocity is specified for positioning in rapid traverse (G00).	
Parameter	getriebe[i].vb_eilgang	
Data type	UNS32	
Data range	$1 \leq vb_eilgang \leq P-AXIS-00212$	
Axis types	T, R, S	
Dimension	T: $\mu\text{m/s}$	R,S: $0.001^\circ/\text{s}$
Default value	166666	
Drive types	----	
Remarks		

Curve-controlled acceleration of spindles

A gear speed specific acceleration curve is defined by the following parameters. This functionality is only possible for axes of the spindle type with endless rotation.

P-AXIS-00202	Type of the characteristic acceleration curve	
Description	The parameter defines the type of the characteristic acceleration curve.	
Parameter	getriebe[i].beschl_kennlinie.typ	
Data type	UNS32	
Data range	0: No characteristic curve acceleration is active, acceleration profile acc. to P-AXIS-00270 1: Hyperbola 2: Polynomial 3: Asynchronous drive	
Axis types	S	
Dimension		S: ----
Default value	0	
Drive types	----	
Remarks		

P-AXIS-00130	Limit speed of the acceleration curve	
Description	The parameter defines the limit speed from which onwards the acceleration is specified in a polynomial or hyperbolic form (see P-AXIS-00202).	
Parameter	getriebe[i].beschl_kennlinie.n_grenz	
Data type	UNS32	
Data range	$0 < n_grenz \leq \text{MAX}(\text{UNS32})$	
Axis types	S	
Dimension		S: 10^{-3}°/s
Default value	0	
Drive types	----	
Remarks		

P-AXIS-00007	Constant acceleration in the range $n < n_{\text{grenz}}$	
Description	The parameter defines a constant acceleration in the range $n < n_{\text{grenz}}$	
Parameter	getriebe[i].beschl_kennlinie.a_konst	
Data type	UNS32	
Data range	$0 \leq a_{\text{konst}} \leq \text{MAX}(\text{UNS32})$	
Axis types	S	
Dimension		S: °/s ²
Default value	0	
Drive types	----	
Remarks		

P-AXIS-00010	Minimum value of acceleration which may not be undershot.	
Description	The parameter defines the minimum value of acceleration, which may not be undershot.	
Parameter	getriebe[i].beschl_kennlinie.a_min	
Data type	UNS32	
Data range	$0 \leq a_{\text{min}} \leq \text{MAX}(\text{UNS32})$	
Axis types	S	
Dimension		S: °/s ²
Default value	0	
Drive types	----	
Remarks		

P-AXIS-00026	Parameter of the a(n) Polynomial (B1)	
Description	B1 parameter of the a(n) polynomial	
Parameter	getriebe[i].beschl_kennlinie.b1	
Data type	REAL64	
Data range	REAL64 range	
Axis types	S	
Dimension		S: 1/s
Default value	0	
Drive types	----	

P-AXIS-00027	Parameter of the a(n) Polynomial (B2)	
Description	B2 parameter of the a(n) polynomial	
Parameter	getriebe[i].beschl_kennlinie.b2	
Data type	REAL64	
Data range	REAL64 range	
Axis types	S	
Dimension		S: 1/°
Default value	0	
Drive types	----	

P-AXIS-00028	Parameter of the a(n) Polynomial (B3)	
Description	B3 parameter of the a(n) polynomial	
Parameter	getriebe[i].beschl_kennlinie.b3	
Data type	REAL64	
Data range	REAL64 range	
Axis types	S	
Dimension		S: s/°²
Default value	0	
Drive types	----	

P-AXIS-00240	Maximum acceleration for acceleration curve of type 3 (P-AXIS-00202)	
Description	This acceleration value is used in constant range with $n < N1$.	
Parameter	getriebe[i].beschl_kennlinie.a_max	
Data type	REAL64	
Data range	$0 \leq a_max \leq P\text{-}AXIS\text{-}00008$	
Axis types	S	
Dimension		S: °/s²
Default value	0	
Drive types	----	
Remarks		

P-AXIS-00241	Speed limit 1 for acceleration curve of type 3 (P-AXIS-00202)	
Description	Above this speed the transition to curve characteristic becomes proportional to $1/n$.	
Parameter	getriebe[i].beschl_kennlinie.n1	
Data type	REAL64	
Data range	$0 \leq n1 \leq P\text{-}AXIS\text{-}00242$	
Axis types	S	
Dimension		S: $10^{-3} \text{ }^\circ/\text{s}$
Default value	0	
Drive types	----	
Remarks		

P-AXIS-00242	Speed limit 2 for acceleration curve of type 3 (P-AXIS-00202)	
Description	Above this speed the transition to curve characteristic becomes proportional to $1/n^2$.	
Parameter	getriebe[i].beschl_kennlinie.n2	
Data type	REAL64	
Data range	$0 \leq n2 \leq P\text{-}AXIS\text{-}00212$	
Axis types	S	
Dimension		S: $10^{-3} \text{ }^\circ/\text{s}$
Default value	0	
Drive types	----	
Remarks		

Referencing

P-AXIS-00156	Homing without cam	
Description	A changeover of homing strategy can be carried out so that homing is done without cam (e.g. only with zero pulse), i.e. without reverting. In this case the parameter P-AXIS-00156 should be set to TRUE.	
Parameter	kenngr.ref_ohne_nocken	
Data type	BOOLEAN	
Data range	0/1	
Axis types	T, R, S	
Dimension	T: ----	R,S: ----
Default value	0	
drive types.	Conventional, Terminal, Lightbus, Profidrive	
Remarks	To be assigned for analogue spindles only. If P-AXIS-00156 is assigned with 1 (TRUE), then it is imperative that P-AXIS-00157 is assigned with 1 (TRUE).	

P-AXIS-00157	Homing without reverting	
Description	Via parameter P-AXIS-00157 a restriction of homing can occur that will prohibit any reverting.	
Parameter	kenngr.ref_ohne_rev	
Data type	BOOLEAN	
Data range	0/1	
Axis types	T, R, S	
Dimension	T: ----	R,S: ----
Default value	0	
drive types.	Conventional, Terminal, Lightbus, Profidrive	
Remarks	The speed during reversing is set with the parameter P-AXIS-00064 (fast_from_cam). By reverting, it is possible to repeatedly move to the reference cam at slow speed. To be assigned for analogue spindles only. P-AXIS-00157 must be assigned with 1 (TRUE) if P-AXIS-00156 is assigned with 1 (TRUE).	

Gear change

P-AXIS-00078	Gear change position	
Description	The gear change position is given by this parameter for every gear step.	
Parameter	getriebe[i].getr_schalt_pos	
Data type	SGN32	
Data range	P-AXIS-00177 < getr_schalt_pos < P-AXIS-00178	
Axis types	T, R, S	
Dimension	T: 0.1 µm	R,S: 0.0001°
Default value	0	
Drive types	----	
Remarks	The definition of this parameter becomes significant when several gear steps are present.	

P-AXIS-00079	Default gear step number	
Description	This parameter defines the gear step number which is supposed to be active at the time of controller start-up.	
Parameter	kenngr.getriebe_stufe	
Data type	UNS16	
Data range	1 ≤ getriebe_stufe < MAX(UNS16)	
Axis types	T, R, S	
Dimension	T: ----	R,S: ----
Default value	1	
Drive types	----	
Remarks		

Direction of rotation of rotary axes

P-AXIS-00224	Restriction of direction of spindle rotation	
Description	If a spindle may only be operated in one direction, then the parameter should be set to 1.	
Parameter	kenngr.vorz_richtung	
Data type	BOOLEAN	
Data range	0/1	
Axis types	R, S	
Dimension		R,S: ----
Default value	0	
Drive types	----	
Remarks		

P-AXIS-00031	Definition of preferred direction of spindle rotation	
Description	If only one direction of rotation is permitted for spindles (P-AXIS-00224), this parameter defines the direction of rotation.	
Parameter	kenngr.beweg_richt	
Data type	BOOLEAN	
Data range	0: Negative direction of rotation 1: Positive direction of rotation	
Axis types	R, S	
Dimension		R,S: ----
Default value	0	
Drive types	----	
Remarks	<p>Positive direction of rotation signifies that coordinate values increase. Negative direction of rotation signifies that coordinate values decrease.</p> <p>This parameter is used only if the parameter P-AXIS-00224 is assigned the value 1.</p>	

Sensorless spindles

P-AXIS-00206	Normalisation of command velocity (numerator)	
Description	<p>The conversion factor of the command velocity to drive format is defined by specifying the value output to the drive and the related distance covered in the time specified in P-AXIS-00207 .</p> <p>This parameter specifies the conversion factor numerator. (P-AXIS-00205 is the denominator)</p> <p>The factor indicates the number of velocity increments output.</p>	
Parameter	antr.v_reso_num	
Data type	UNS32	
Data range	$0 \leq v_reso_num \leq \text{MAX}(\text{UNS32})$	
Axis types	T, R, S	
Dimension	T: increments	R,S: increments
Default value	1	
Drive types	All drive types	
Remarks		

P-AXIS-00205	Normalisation of the velocity (denominator)	
Description	<p>The conversion factor of the set velocity to drive format is obtained by specifying the value output to the drive and the related path distance covered in the time specified in P-AXIS-00207 .</p> <p>This parameter specifies the conversion factor denominator. (P-AXIS-00206 is the numerator)</p> <p>This parameter indicates the path covered in the time specified in P-AXIS-00207, provided the value in P-AXIS-00206 is output to the drive. The path is specified in 1 μm or 0.001°.</p>	
Parameter	antr.v_reso_denom	
Data type	UNS32	
Data range	$1 \leq v_reso_denom \leq \text{MAX}(\text{UNS32})$	
Axis types	T, R, S	
Dimension	T: 1 μm	R,S: 0,001°
Default value	36	
Drive types	All drive types	
Remarks		

P-AXIS-00207	Time base for normalisation of velocity	
Description	The time base for adapting the velocity interface to the unit used in the drive can be specified as value per minute, second or sampling interval. If normalisation per sampling interval is selected, the output value changes proportionally depending on the CNC cycle time at constant velocity. This may be essential depending on the drive.	
Parameter	antr.v_time_base	
Data type	UNS16	
Data range	0: per minute 1: per second 2: per sampling interval	
Axis types	T, R, S	
Dimension	T: ----	R,S: ----
Default value	0	
Drive types	SERCOS	
Remarks		

P-AXIS-00265	Velocity limit for switching to velocity controlled mode	
Description	If any spindle revolution higher than the given limit is commanded, the operation mode is switched to velocity control automatically.	
Parameter	antr.velocity_position_control_on	
Data type	SGN32	
Data range	$0 \leq \text{velocity_position_control_on} \leq \text{MAX}(\text{SGN32})$	
Axis types	S	
Dimension		S: 0.001°/s
Default value	2000000000	
Drive types	SERCOS	
Remarks	For a sensorless spindle only a velocity of 0 is useful. Therefore the command velocity of the interpolator is always output and not the setpoint velocity of the position controller.	

P-AXIS-00266	Velocity limit for switching back to position control	
Description	If the actual revolution during any positioning via M19 is higher than the given limit, the spindle is first decelerated to the limit. Afterwards the operation mode is switched back to position control.	
Parameter	antr.velocity_position_control_off	
Data type	SGN32	
Data range	$0 \leq \text{velocity_position_control_off} \leq \text{MAX}(\text{SGN32})$	
Axis types	S	
Dimension		S: 0.001°/s
Default value	0	
Drive types	SERCOS	
Remarks	For a sensorless spindle only a velocity of 0 is useful Therefore the command velocity of the interpolator is always output and not the setpoint velocity of the position controller.	

3.2.3 Tool parameters

Dynamic data

Depending on the application, it may be necessary to define specific dynamic data for some tools. This data is used in the spindle to limit speed and acceleration during machining. The logical axis number of the spindle must also be specified in order to transmit the dynamic data to the spindle with the assigned tool.

P-TOOL-00012	Logical spindle axis number
Description	<p>The dynamic data of the tool is assigned by the logical axis number of the spindle which will carry the tool after it is changed.</p> <p>If the logical axis number is assigned the value 0, no dynamic data is transferred to the spindle when the tool is changed.</p> <p>Dynamic data is modal in the spindle. It can either be overwritten</p> <ul style="list-style-type: none"> • by the dynamic data of a new tool or • be reset by S[DEFAULT_DYNAMIK_DATA] to the default values configured.
Parameter	wz[i].log_ax_nr_spdl
Data type	UNS16
Data range	$0 \leq \text{log_ax_nr_spdl} \leq \text{MAX(UNS16)}$
Dimension	----
Default value	0
Remarks	<p>Parameterisation example: Assigning the dynamic data of Tool 5</p> <p><i>wz[5].log_ax_nr_spdl 6 #Logical axis number of the spindle</i></p>

P-TOOL-00013	Minimum rotation speed
Description	Minimum tool rotation speed.
Parameter	wz[i].vb_min
Data type	REAL64
Data range	$0 \leq \text{vb_min} \leq \text{P-TOOL-00014}$
Unit	0.001°/s
Default value	0
Remarks	<p>The minimum rotation speed is only limited for endless turning.</p> <p>Parameterisation example: Assigning the dynamic data of Tool 5</p> <p><i>wz[5].vb_min 60000 #Minimum rotation speed</i></p>

P-TOOL-00014	Maximum rotation speed
Description	Maximum tool rotation speed.
Parameter	wz[i].vb_max
Data type	REAL64
Data range	$1 \leq vb_max \leq 2000000000$
Unit	0.001°/s
Default value	1
Remarks	Parameterisation example: Assigning the dynamic data of Tool 5 <i>wz[5].vb_max 3000000 #Maximum rotation speed</i>

P-TOOL-00015	Maximum acceleration
Description	Maximum tool acceleration.
Parameter	wz[i].a_max
Data type	REAL64
Data range	$1 \leq a_max \leq 100000000$
Unit	°/s ²
Default value	1
Remarks	Parameterisation example: Assigning the dynamic data of Tool 5 <i>wz[5].a_max 3000 #Maximum acceleration</i>

4 Appendix

4.1 Suggestions, corrections and the latest documentation

Did you find any errors? Do you have any suggestions or constructive criticism? Then please contact us at documentation@isg-stuttgart.de. The latest documentation is posted in our Online Help (DE/EN):



QR code link: <https://www.isg-stuttgart.de/documentation-kernel/>

The link above forwards you to:

<https://www.isg-stuttgart.de/fileadmin/kernel/kernel-html/index.html>



Notice

Change options for favourite links in your browser;

Technical changes to the website layout concerning folder paths or a change in the HTML framework and therefore the link structure cannot be excluded.

We recommend you to save the above "QR code link" as your primary favourite link.

PDFs for download:

DE:

<https://www.isg-stuttgart.de/produkte/softwareprodukte/isg-kernel/dokumente-und-downloads>

EN:

<https://www.isg-stuttgart.de/en/products/softwareproducts/isg-kernel/documents-and-downloads>

E-Mail: documentation@isg-stuttgart.de

Keyword index

P	
P-AXIS-00007	86
P-AXIS-00010	86
P-AXIS-00015	76
P-AXIS-00016	76
P-AXIS-00018	77
P-AXIS-00020	77
P-AXIS-00026	86
P-AXIS-00027	87
P-AXIS-00028	87
P-AXIS-00031	91
P-AXIS-00078	90
P-AXIS-00079	90
P-AXIS-00099	80
P-AXIS-00120	82
P-AXIS-00124	82
P-AXIS-00125	82
P-AXIS-00126	81
P-AXIS-00127	81
P-AXIS-00128	80
P-AXIS-00129	79
P-AXIS-00130	85
P-AXIS-00156	89
P-AXIS-00157	89
P-AXIS-00159	78
P-AXIS-00202	85
P-AXIS-00205	92
P-AXIS-00206	92
P-AXIS-00207	93
P-AXIS-00209	84
P-AXIS-00216	83
P-AXIS-00217	84
P-AXIS-00220	83
P-AXIS-00224	91
P-AXIS-00233	79
P-AXIS-00234	78
P-AXIS-00240	87
P-AXIS-00241	88
P-AXIS-00242	88
P-AXIS-00265	93
P-AXIS-00266	94
P-CHAN-00004	72
P-CHAN-00007	68
P-CHAN-00008	67
P-CHAN-00010	65
P-CHAN-00036	67
P-CHAN-00037	74
P-CHAN-00038	74
P-CHAN-00043	71
P-CHAN-00045	69
P-CHAN-00047	70
P-CHAN-00049	70
P-CHAN-00051	66
P-CHAN-00052	71
P-CHAN-00053	66
P-CHAN-00055	73
P-CHAN-00058	73
P-CHAN-00061	75
P-CHAN-00069	68
P-CHAN-00074	72
P-CHAN-00081	69
P-CHAN-00082	65
P-TOOL-00012	95
P-TOOL-00013	95
P-TOOL-00014	96
P-TOOL-00015	96



© Copyright
ISG Industrielle Steuerungstechnik GmbH
STEP, Gropiusplatz 10
D-70563 Stuttgart
All rights reserved
www.isg-stuttgart.de
support@isg-stuttgart.de

